

ITEM 項目	PARTS NAME 零件名稱	Q'TY 數量	MATERIAL 材質	FINISH/REMARK 處理/備註
1	HOUSING	1	HIGH TEMP PLASTIC	UL-94V-0 (Black)
2	CONTACT	10	COPPER ALLOY	Contact area: Au:0.5u", Solder tails: Tin100u", Ni:50u"
3	GND PIN	2	COPPER ALLOY	Solder tails: Tin100u", Ni:50u"

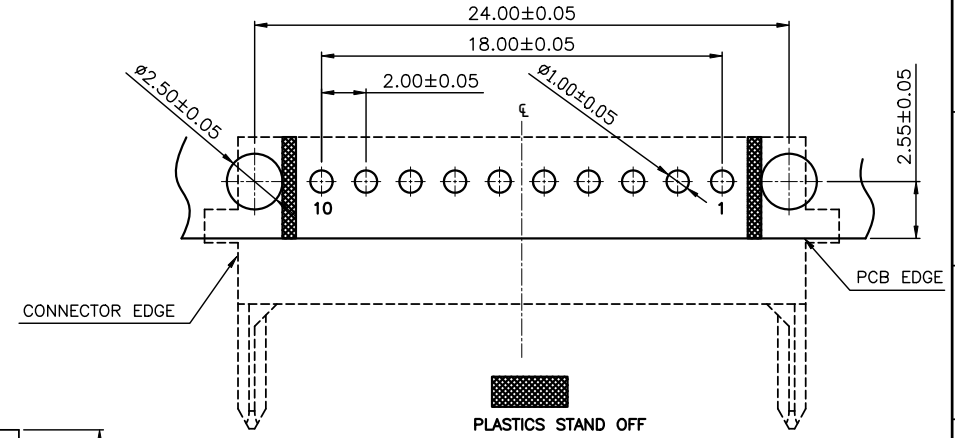

RECOMMENDED P.C.B LAYOUT (COMPONENT SIDE)
P.C.B THICKNESS=1.20mm
WITHOUT LOCKING FUNCTION

- NOTES
- MATERIAL: See drawing
 - ELECTRICAL
 - Insulator resistance: 1000M ohms Min. @ 250 VDC
 - Withstanding voltage: 500 VDC / minute
 - Contact resistance: 30m ohms Max.
 - MECHANICAL
 - Mating force: 20N(2.0kgf) Max.
 - Unmating force: 3.0N(0.3kgf) Min.
 - Durability: 1000 cycles Min.
 - Contact retention force: 5.0N(0.5kgf) Min
 - Rating: DC 30V/7A(PER PIN)
 - Operating temperature: -40°C ~ +105°C
 - PART NO.

M30	-	0876	-	0	0	051
SERIES		Connector		MODEL NO.		MATERIAL TYPE
		0876				051=Type 051 "0" =Semi-finished goods



WALTA 華大電子股份有限公司
WALTA ELECTRONIC CO.,LTD.
TEL:886-2-26577778;FAX:886-2-26575659

REV. 版本	ECN NO. 設變號碼	MARK 記號	REVISIONS 設變內容	SIGN 修改	DATE 日期	UNLESS OTHERWISE SPECIFIED TOLERANCE 尺寸公差 X. ±0.50 .X ±0.30 .XX ±0.20 ANG. ±5'00'	CHECKED 審核	DESIGNED 設計 London 2024/8/28	TITLE 產品名稱 Battery 10PIN - Male
A	EXXXX-XXX	△ X 0	新開	London	2024/8/28		APPROVED 承認	DRAWN 製圖 London 2024/8/28	UNIT 單位 MM SCALE 比例 1/1 SIZE 尺寸 A4
									PART NO. 產品料號 M30-0876-00051 DOC. NO. 文件編號 CUT-0876-002
									SHEET 頁碼 1/2 REV. 版本 A

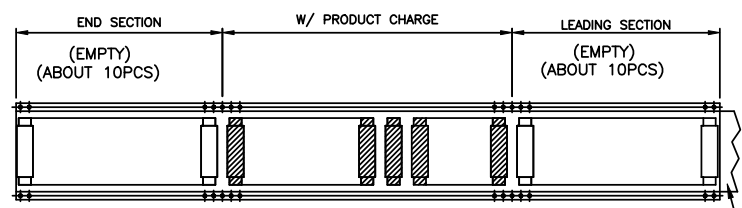
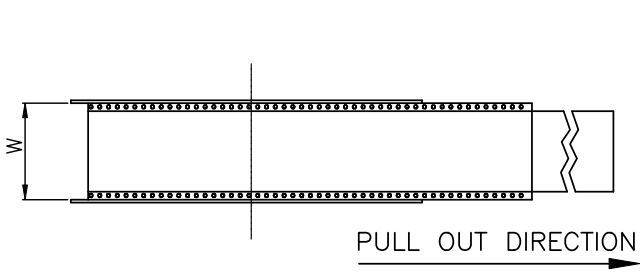

ITEM 項目	PARTS NAME 零件名稱	FINISH/REMARK 處理/備註
1	I/O CONNECTOR	1800 PCS/BOX(REFERENCE)
2	BOX	6 REEL/BOX
3	WATERPROOF BAG	1 PCS
4	REEL	--
5	COVER TAPE	(COLOR:TRANSPARENT)
6	CARRIER TAPE	300 PCS/REEL(REFERENCE)
7	LABEL	批號標籤

TOP COVER TAPE

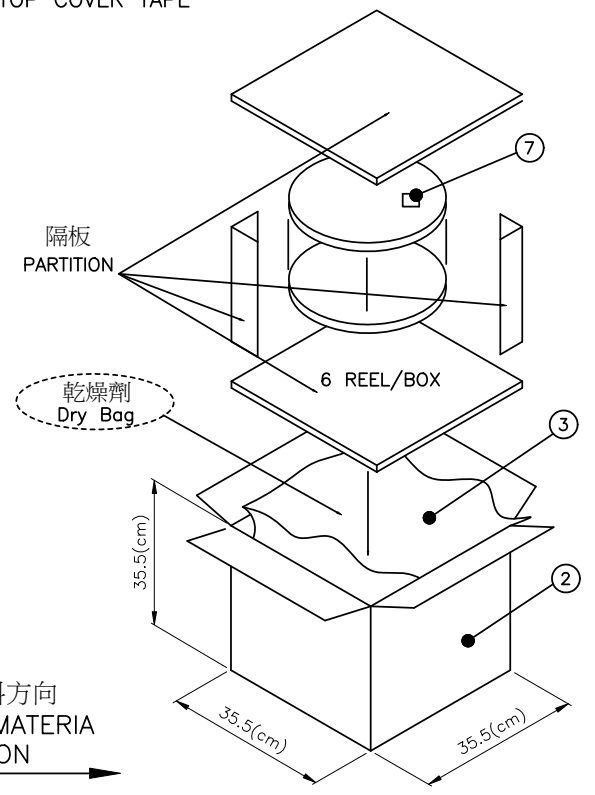
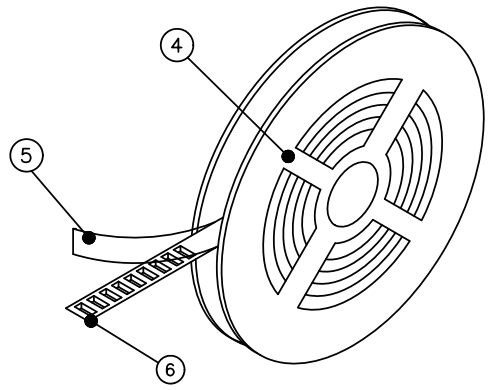
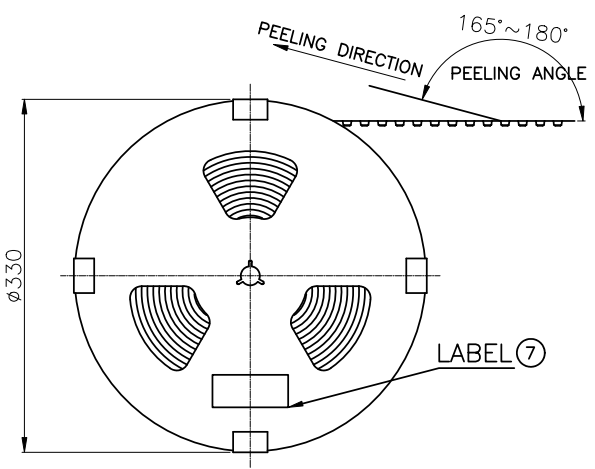

客戶放料方向
INPUT MATERIA
DIRECTION

收料方向
CATHETER MATERIAL
DIRECTION

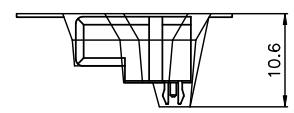
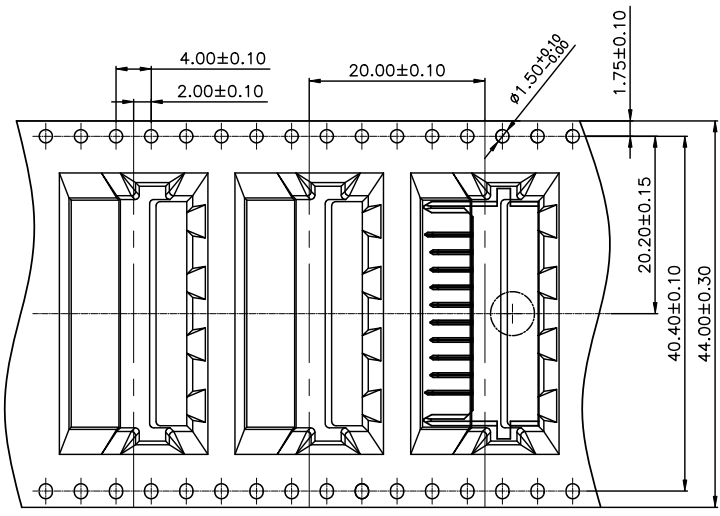

TAPE REEL成品擺放方向

- NOTES
- 1.MATERIAL: PS (Color: 透明)
 - 2.DEFORMATION(變形)&DAMAGE(損壞): NA.(不可)
 - 3.All dimensions meet EIA-481-C requirements.

Process Capable

RoHS Compliant

WALTA

華大電子股份有限公司
WALTA ELECTRONIC CO.,LTD.
TEL:886-2-26577778;FAX:886-2-26575659

REV. 版本	ECN NO. 設變號碼	MARK 記號	REVISIONS 設變內容	SIGN 修改	DATE 日期	UNLESS OTHERWISE SPECIFIED TOLERANCE 尺寸公差	CHECKED 審核	DESIGNED 設計	UNIT 單位	TITLE 產品名稱
A	EXXXX-XXX	△ X 0	新開	Lonlon	2024/8/28	X. ±0.50 .X ±0.30 .XX ±0.20 ANG. ±5'00"	APPROVED 承認	Lonlon 2024/8/28	MM	包裝規範
								Lonlon 2024/8/28	SCALE 比例 1/1 SIZE A4	PART NO. 產品料號 M30-0876-00051 DOC. NO. 文件編號 CUT-0876-002
										SHEET 頁碼 2/2 REV. 版本 A