

CONNECTOR EDGE  
RECOMMENDED P.C.B LAYOUT (COMPONENT SIDE)  
P.C.B THICKNESS=1.20mm  
WITHOUT LOCKING FUNCTION

ITEM 項目	PARTS NAME 零件名稱	Q'TY 數量	MATERIAL 材質	FINISH/REMARK 處理/備註
1	HOUSING	1	HIGH TEMP PLASTIC	UL-94V-0 (Black)
2	CONTACT	20	COPPER ALLOY	Contact area: Au:0.5u", Solder tails: Tin100u", Ni:50u"
3	MYLAR	1	HIGH TEMP MATERIALS	Colour: amber

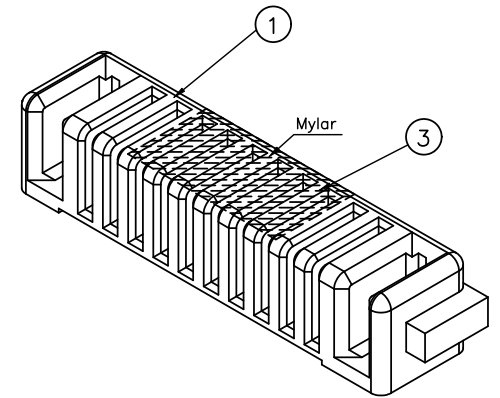

- NOTES
- MATERIAL: See drawing
  - ELECTRICAL
    - Insulator resistance: 1000M ohms Min. @ 250 VDC
    - Withstanding voltage: 500 VDC / minute
    - Contact resistance: 30m ohms Max.
  - MECHANICAL
    - Mating force: 20N(2.0kgf) Max.
    - Unmating force: 3.0N(0.3kgf) Min.
    - Durability: 1000 cycles Min.
    - Contact retention force: 5.0N(0.5kgf) Min
  - Rating: DC 30V/7A(PER PIN)
  - Operating temperature: -40°C ~ +105°C
  - PART NO.
 

M30	-	0876	-	0	0	001
SERIES	Connector	MODEL NO.	TYPE NO.	PROCESS NO.	MATERIAL TYPE	
0876			00X=Type X	"0"	0=Semi-finished goods	

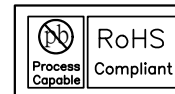

**華大電子股份有限公司**  
**WALTA ELECTRONIC CO.,LTD.**  
TEL:886-2-26577778;FAX:886-2-26575659

A		EXXXX-XXX	△ X 0	-	Lonlon	2024/8/27	UNLESS OTHERWISE SPECIFIED TOLERANCE 尺寸公差 X. ±0.50 .X ±0.30 .XX ±0.20 ANG. ±5'00'	CHECKED 審核 DESIGNED 設計 London 2024/8/27	UNIT 單位 MM	TITLE 產品名稱 Battery 10PIN - Female	
REV. 版本	ECN NO. 設變號碼	MARK 記號	REVISIONS 設變內容	SIGN 修改	DATE 日期			DRAWN 製圖 London 2024/8/27	SCALE 比例 1/1	PART NO. 產品料號 M30-0876-00001	SHEET 頁碼 1/2
1	2	3	4	5	6	7	8	9	10		

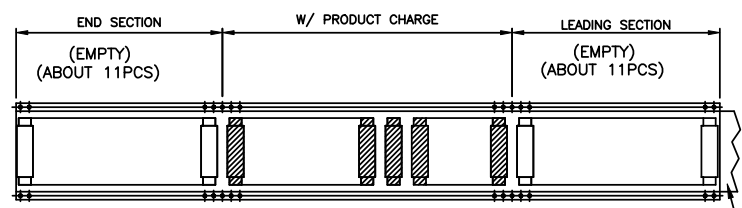
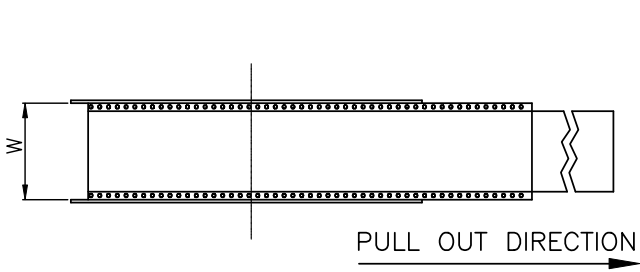

ITEM 項目	PARTS NAME 零件名稱	FINISH/REMARK 處理/備註
1	I/O CONNECTOR	3000 PCS/BOX(REFERENCE)
2	BOX	6 REEL/BOX
3	WATERPROOF BAG	1 PCS
4	REEL	--
5	COVER TAPE	(COLOR:TRANSPARENT)
6	CARRIER TAPE	500 PCS/REEL(REFERENCE)
7	LABEL	批號標籤

TOP COVER TAPE

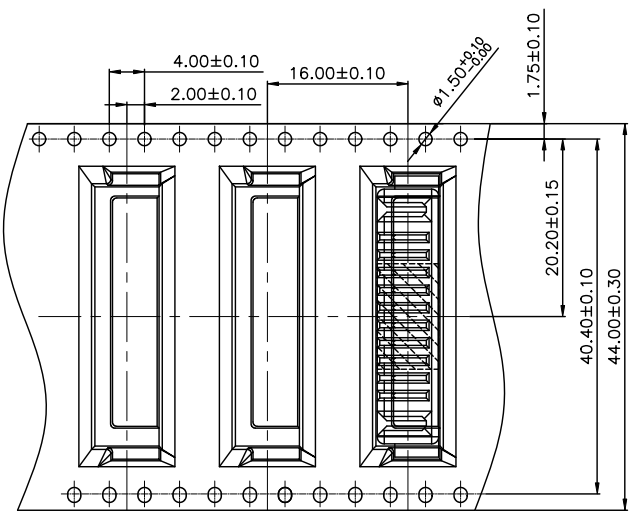
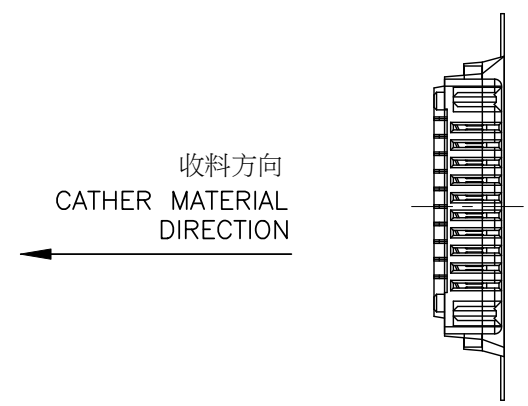
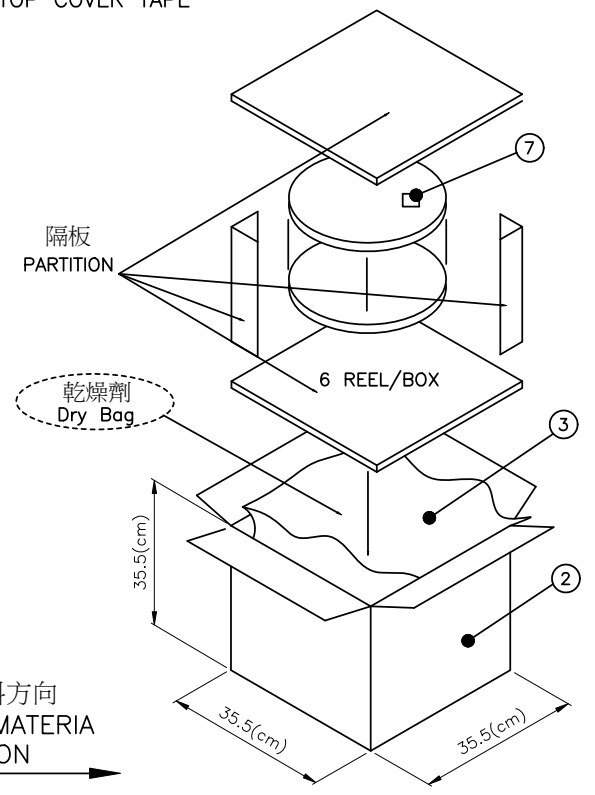
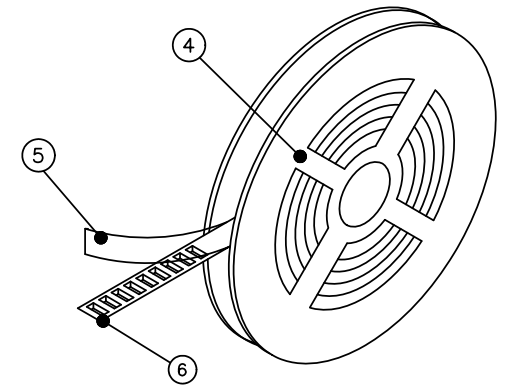
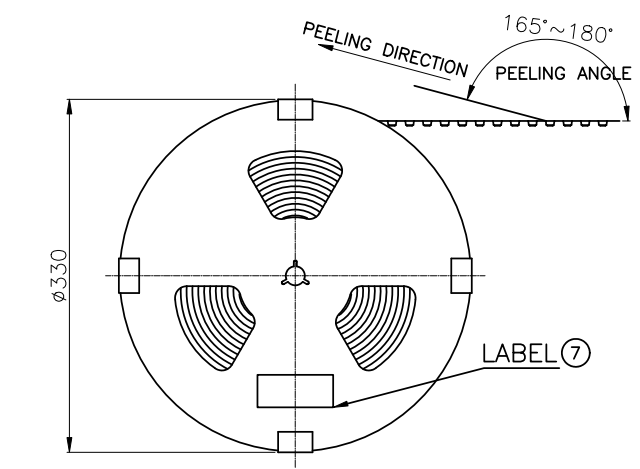

- NOTES
- 1.MATERIAL: PS (Color: 透明)
  - 2.DEFORMATION(變形)&DAMAGE(損壞): NA.(不可)
  - 3.All dimensions meet EIA-481-C requirements.

TAPE REEL成品擺放方向

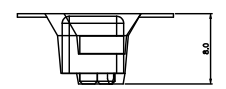

Process Capable

RoHS Compliant

**WALTA**

華大電子股份有限公司  
WALTA ELECTRONIC CO.,LTD.  
TEL:886-2-26577778;FAX:886-2-26575659

REV. 版本	ECN NO. 設變號碼	MARK 記號	REVISIONS 設變內容	SIGN 修改	DATE 日期	UNLESS OTHERWISE SPECIFIED TOLERANCE 尺寸公差	CHECKED 審核	DESIGNED 設計	SCALE 比例	TITLE 產品名稱	PART NO. 產品料號	SHEET 頁碼
A	EXXXX-XXX	△ X 0	新開	Lonlon	2024/8/28	X. ±0.50 .X ±0.30 .XX ±0.20 ANG. ±5'00"	APPROVED 承認	London 2024/8/28	1/1	包裝規範	M30-0876-00001	2/2
								London 2024/8/28	A4	CUT-0876-001		A