

- NOTES:
- MATERIAL:
    - MOLDING: LCP UL94 V-0
    - CONTACT: COPPER ALLOY.
    - PLATED GOLD ON CONTACT AREA,
    - G/F GOLD ON SOLDER AREA,
    - 50u" NICKEL PLATING OVER ALL.
  - SHELL: SUS304, T=0.20±0.03mm
  - 50u" NICKEL PLATING OVER ALL.
  - G/F Foot brushing gold
  - SHELL2: SUS304, T=0.30±0.03mm
  - 50u" NICKEL PLATING OVER ALL.
  - LATCH: SUS301, T=0.15±0.03mm
- MECHANICAL:
    - INSERTION: 5~20N.
    - EXTRACTION: 8~20N.
    - DURABILITY: 10000 CYCLES
  - ELECTRICAL:
    - CURRENT: 5A MAX FOR VBUS;
    - 1.25A FOR GND, 0.25A FOR OTHER OTHER.
    - VOLTAGE: 20VDC MAX
    - WITHSTANDING VOLTAGE: 100V AC.
    - CONTACT RESISTANCE: 40mΩ MAX.
    - INSULATION RESISTANCE: 100MΩ MIN.
  - ENVIRONMENTAL
    - TEMPERATURE RANGE -40°C ~ +85°C

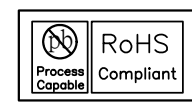

**WALTA** 華大電子股份有限公司  
 WALTA ELECTRONIC CO.,LTD.  
 TEL:886-2-26577778; FAX:886-2-26575659

A		E2410-001	X 0	-		London	2024/10/01	UNLESS OTHERWISE SPECIFIED TOLERANCE 尺寸公差 .X ±0.50 .XX ±0.30 .XXX ±0.20 ANG. ±2'00'	CHECKED 審核 DESIGNED 設計 London 2024/10/01	DESIGNED 設計 London 2024/10/01	UNIT 單位 MM	TITLE 產品名稱 USB TYPE C 板上CL3.40 外壳PH4.0 脚长2.4 DIP脚长1.80 母座	PART NO. 產品料號 D07-C124-02401	SHEET 頁碼 1/3
REV. 版本	ECN NO. 設變號碼	MARK 記號	REVISIONS 設變內容			SIGN 修改	DATE 日期		APPROVED 承認	DRAWN 製圖 London 2024/10/01	SCALE 比例 1/1	DOC. NO. 文件編號 CUT-C124-010	REV. 版本 A	

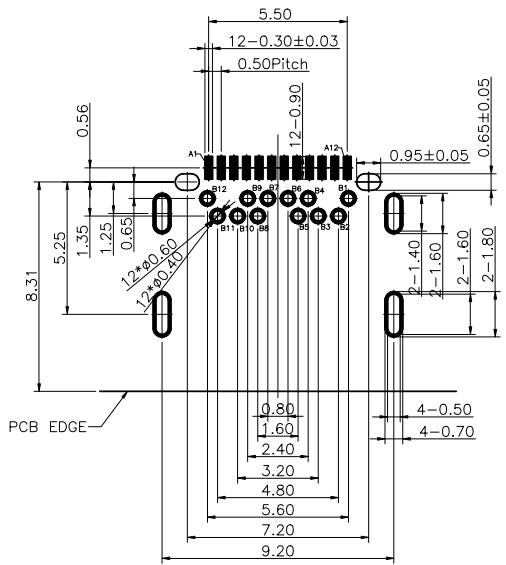

RECOMMENDED PCB LAYOUT(COMPONENT SIDE)  
 PCB THICKNESS: 1.60±0.05  
 DEFAULT TOLERANCE: ±0.05

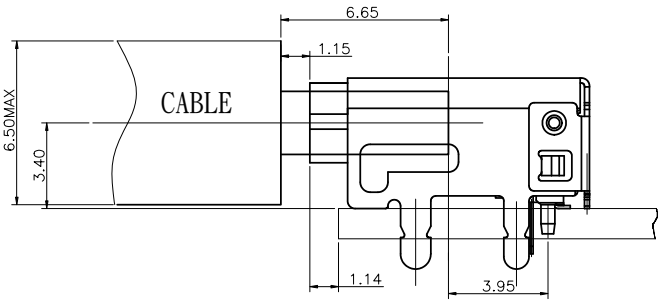
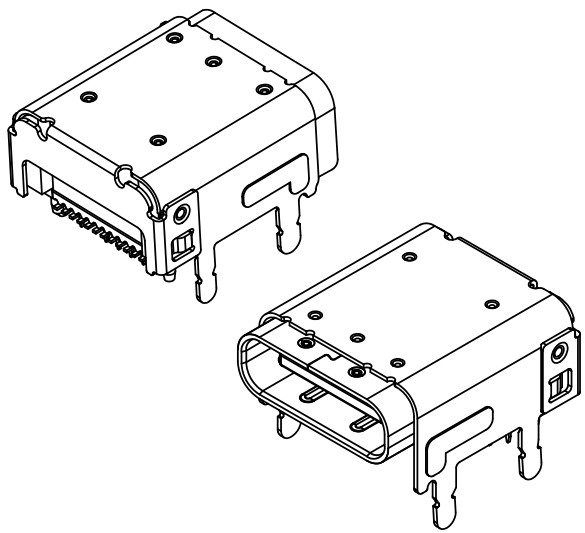

USB TYPE-C FULL-FEATURED RECEPTACLE INTERFACE PIN ASSIGNMENTS

PIN	Signal Name	Description	PIN	Signal Name	Description
A1	GND	Ground return	B12	GND	Ground return
A2	SSTXp1	Positive half of first SuperSpeed TX differential pair	B11	SSRXp1	Positive half of first SuperSpeed RX differential pair
A3	SSTXn1	Negative half of first SuperSpeed TX differential pair	B10	SSRXn1	Negative half of first SuperSpeed RX differential pair
A4	Vbus	Bus Power	B9	Vbus	Bus Power
A5	CC1	Configuration Channel	B8	SBU2	Sideband Use (SBU)
A6	Dp1	Positive half of the USB 2.0 differential pair-Position 1	B7	Dn2	Negative half of the USB 2.0 differential pair-Position 2
A7	Dn1	Negative half of the USB 2.0 differential pair-Position 1	B6	Dp2	Positive half of the USB 2.0 differential pair-Position 2
A8	SBU1	Sideband Use (SBU)	B5	CC2	Configuration Channel
A9	Vbus	Bus Power	B4	Vbus	Bus Power
A10	SSRXn2	Negative half of second SuperSpeed RX differential pair	B3	SSTXn2	Negative half of second SuperSpeed TX differential pair
A11	SSRXp2	Positive half of second SuperSpeed RX differential pair	B2	SSTXp2	Positive half of second SuperSpeed TX differential pair
A12	GND	Ground return	B1	GND	Ground return



**WALTA** 華大電子股份有限公司  
 WALTA ELECTRONIC CO.,LTD.  
 TEL.886-2-26577778;FAX.886-2-26575659

UNLESS OTHERWISE SPECIFIED TOLERANCE 尺寸公差		CHECKED 審核	DESIGNED 設計	TITLE 產品名稱	
X. ±0.50			London	USB TYPE C 板上CL3.40 外壳PH4.0 脚长2.4 DIP脚长1.80 母座	
.X ±0.30		APPROVED 承認	2024/10/01	UNIT 單位	MM
.XX ±0.20				SCALE 比例	1/1
.XXX ±0.10				PART NO. 產品料號	D07-C124-02401
ANG. ±2'00'				DOC. NO. 文件編號	CUT-C124-010
REVISIONS 設變內容	SIGN 修改	DATE 日期	DRAWN 製圖	SHEET 頁碼	2/3
A E2410-001	London	2024/10/01	London	REV. 版本	A

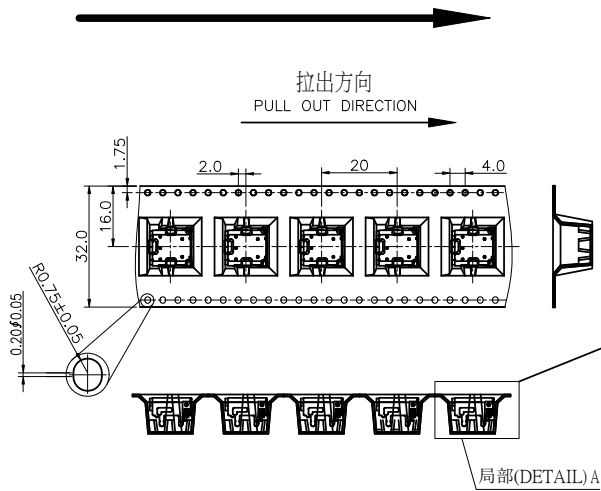
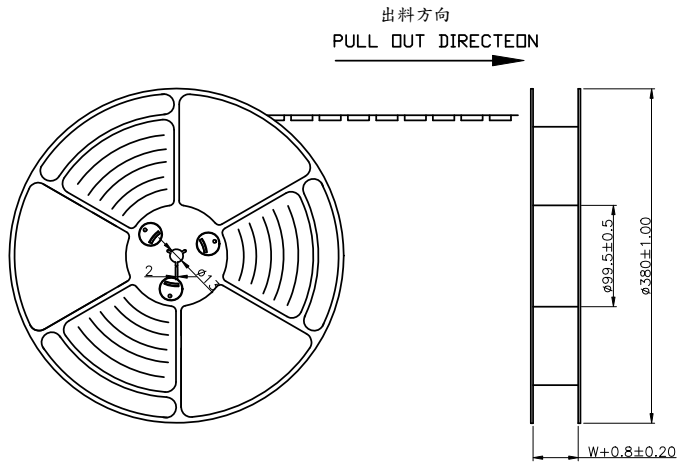
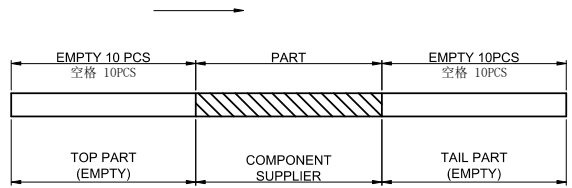

局部(Detail) A  
2:1

产品放置方式示意图  
PLACE PRODUCT AREA

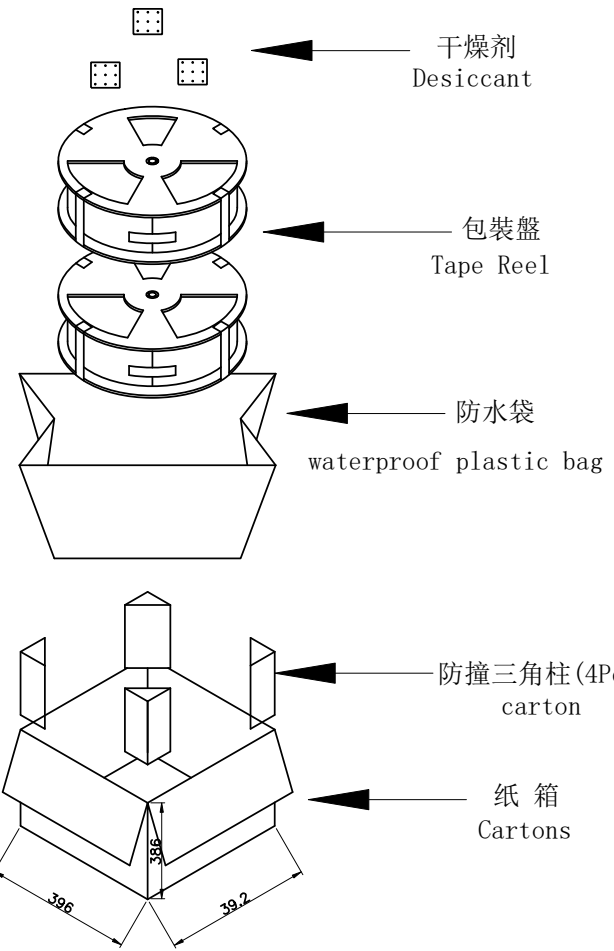

产品料号 (PRODUCT No.)	包装数量 (PACKING CAPACITY)			重量 WEIGHT (Kg)		
	PCS/REEL	REELS/CARTON	PCS/CARTON	N.W./PCS	N.W./BOX	G.W./BOX
	550	10	5500	0.824	11.0	12.0



華大電子股份有限公司  
WALTA ELECTRONIC CO.,LTD.  
TEL:886-2-26577778;FAX:886-2-26575659

REV. 版本	ECN NO. 設變號碼	MARK 記號	REVISIONS 設變內容	SIGN 修改	DATE 日期
A	E2410-001	X 0		London	2024/10/01

UNLESS OTHERWISE SPECIFIED TOLERANCE 尺寸公差	
X.	$\pm 0.50$
.X	$\pm 0.30$
.XX	$\pm 0.20$
.XXX	$\pm 0.10$
ANG.	$\pm 2'00$

CHECKED 審核	DESIGNED 設計
	London 2024/10/01
APPROVED 承認	DRAWN 製圖
	London 2024/10/01

UNIT 單位	SCALE 比例	SIZE 尺寸
MM	1/1	A4

TITLE 產品名稱	PART NO. 產品料號	SHEET 頁碼
USB TYPE C 板上CL3.40 外壳PH4.0 脚长2.4 DIP脚长1.80 母座	D07-C124-02401	3/3
DOC. NO. 文件編號	REV. 版本	
CUT-C124-010	A	