

Contact Number	Signal Name
PIN1	VBUS
PIN2	D-
PIN3	D+
PIN4	GND
PIN5	StdA_SSRX-
PIN6	StdA_SSRX+
PIN7	GND_DRAIN
PIN8	StdA_SSTX-
PIN9	StdA_SSTX+
Shell	Shield

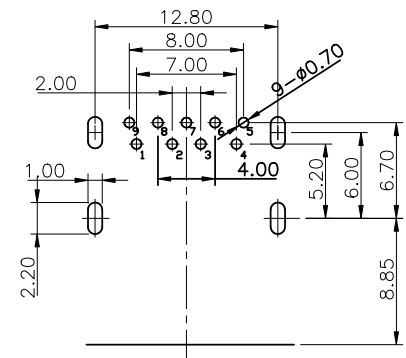
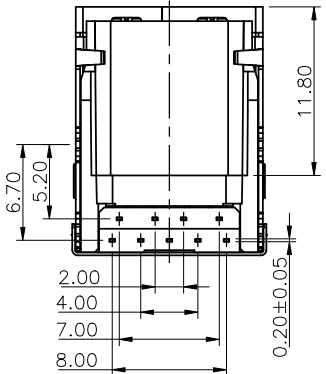
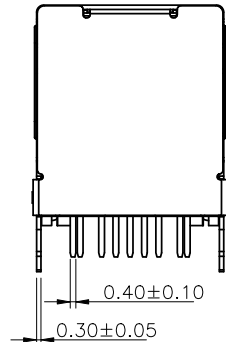
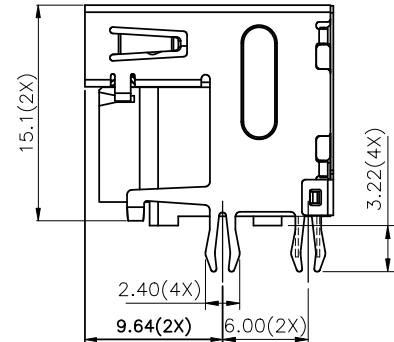
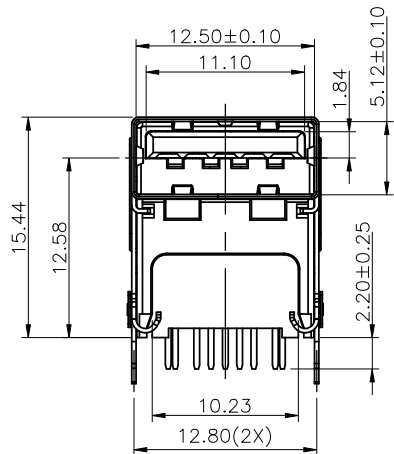
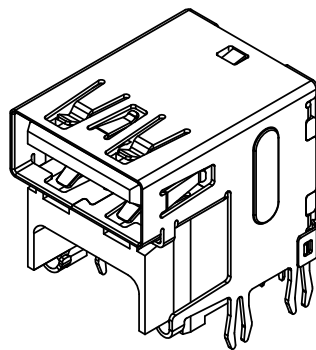

RECOMMEND P.C.B LAYOUT (TOLERANCES ±0.05mm)  
(COMPONENT SIDE) THICKNESS=1.6mm

NOTE:

- MATERIAL:
  - HOUSING: PA66 UL94-V0,Blue
  - MOLDING HOUSING: PA66 UL94-V0,Blue
  - CONTACT 4PIN:C5191 (T=0.25mm)
  - CONTACT 5PIN:C2680 (T=0.20mm)
  - FRONT SHELL:SUS304(T=0.30mm)
  - BACK SHELL: SUS304(T=0.20mm)
- PLATING SPECIFICATION:
  - USB 3.1 TERMINAL:
    - Ni 50u"Min. UNDER PLATED,
    - Au1u" PLATED ON THE CONATCT AREA.
    - AND MATTE TIN 80u"Min. PLATED ON THE SOLDER TALL.
  - FRONT SHELL
    - Ni 50u" Min. UNDER PLATED ON SOLDER AREA,
    - MATTE TIN 80u: Min. PLATED ON SOLDER AREA.
  - BACK SHELL: CLEANING.
- MECHANICAL CHARACTERISTICS:
  - INSERTION FORCE: 35N Max.
  - WITHDRAWAL FORCE: 10N Min. INTIAL AND 8N Min. AFTER THE SPECIFIED INSERTION/EXTRACTION OR DURABILITY CYCLES (AT A MAX. RATE OF 12.5MM/MINUTE)
  - DURABILITY: 5,000 CYCLES
- ELECTRICAL CHARACTERISTICS:
  - CONTACT RESISTANCE: 30mΩ Max FOR INITIAL.
  - CONTACT CURRENT RATING: 1.8A FOR VBUS AND GND PIN; OTHER PINS:0.25A/PIN
  - DIELECTRIC WITHSTANDING VOLTAGE: 100V AC R.M.S.
  - INSULATION RESISTANCE 100MΩ Min
  - OPERATING TEMPERATURE: -40°C ~ 85°C
- WAVE SOLDER:
 

THE CONNECTOR SHALL BE MOUNTED ON THE PCB, THE TEMPERATURE OF THE SOLDER SHALL BE 270°C AND IMMERSION DURATION 10 SECONDS.
- PART NO.
 

D 01 - C 124 - 009 01

SERIES D 01 - C 124 - 009 01 TYPE NO. 01=Type 1  
 D=I/O Connector CONN TYPE NO. 01=type 1  
 FORM OF FACTORY C=Connector of factory



**華大電子股份有限公司**  
**WALTA ELECTRONIC CO.,LTD.**  
 TEL:886-2-26577778;FAX.886-2-26575659

A		E2410-004	X 0	-	zhijun	2024/8/15	UNLESS OTHERWISE SPECIFIED TOLERANCE 尺寸公差 X. ±0.50 .X ±0.30 .XX ±0.20 ANG. ±5°00'	CHECKED 審核	DESIGNED 設計 zhijun 2024/8/15	TITLE 產品名稱 USB 3.1 A/F 90°架高DIP CH=12.58mm UNIT 單位 MM SCALE 比例 1/1 SIZE 尺寸 A4	PART NO. 產品料號 D01-C124-00901 DOC. NO. 文件編號 CUT-C124-012 REV. 版本 1/2 A
REV. 版本	ECN NO. 設變號碼	MARK 記號		REVISIONS 設變內容	SIGN 修改	DATE 日期			DRAWN 製圖 zhijun 2024/8/15		

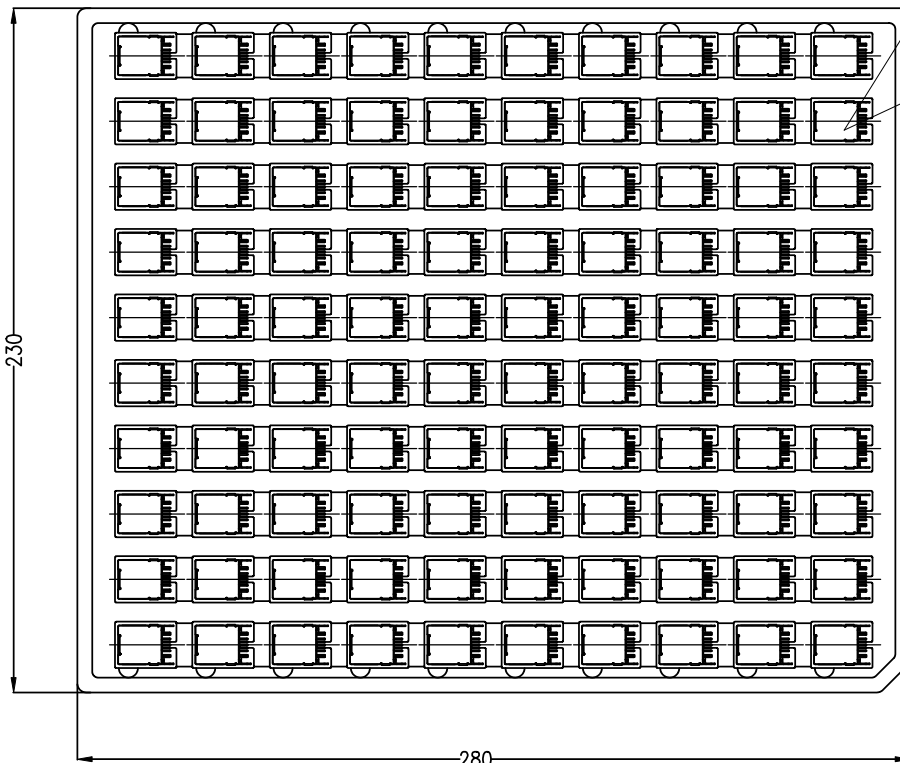
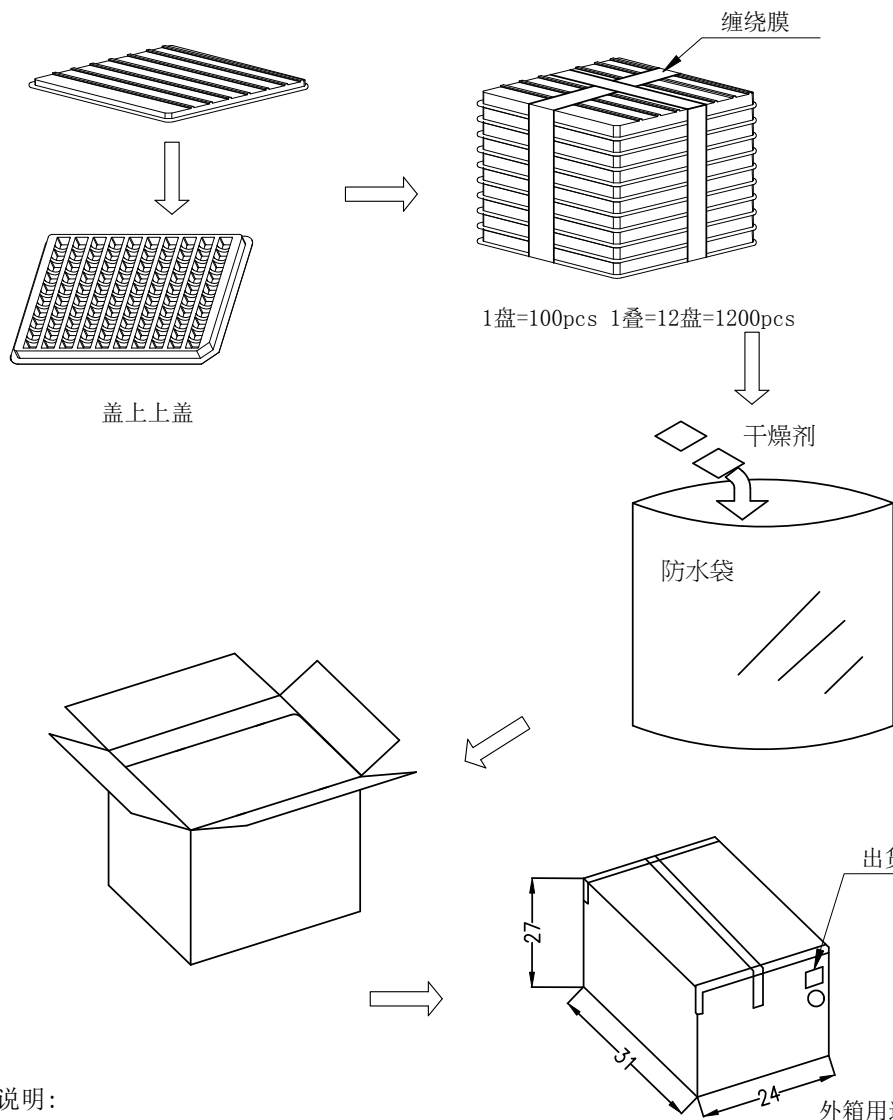

产品放入盘内，端子焊脚朝右，100 PCS/TRAY

包装说明:

1. 吸塑盘规格: 280\*230\*14, 100PCS/盘, 每一盘盖1PCS盘盖;
2. 每12盘为一叠, 每叠以十字包装捆扎,
3. 若客户另有贴标签要求, 则按其订单注明之要求贴;
4. 纸箱规格: 310\*240\*270, 每箱数量为1200PCS;
5. 封盖后以封箱胶封箱, 外箱贴上出货标签;
6. 若客户另有贴标签要求, 则按其订单注明之要求贴;
7. 未满足之零数箱需以缓冲材料填满;

外箱用透明胶带封“工”字型。  
按客户要求贴产品或其它标签。



**WALTA** 華大電子股份有限公司  
WALTA ELECTRONIC CO.,LTD.  
TEL:886-2-26577778;FAX:886-2-26575659

UNLESS OTHERWISE SPECIFIED TOLERANCE 尺寸公差		CHECKED 審核		DESIGNED 設計		TITLE 產品名稱	
X.	±0.50			zhijun		USB 3.1 A/F 90°架高DIP CH=12.58mm	
.X	±0.30	APPROVED 承認		2024/8/15		2/2	
.XX	±0.20			DRAWN 製圖		SCALE 比例	
ANG.	±5°00'			zhijun		1/1	
REV. 版本		ECN NO. 設變號碼		MARK 記號		PART NO. 產品料號	
1		2		3		D01-C124-00901	
3		4		5		DOC. NO. 文件編號	
3		4		5		CUT-C124-012	
3		4		5		A	