

P/N:M22-0577-10001

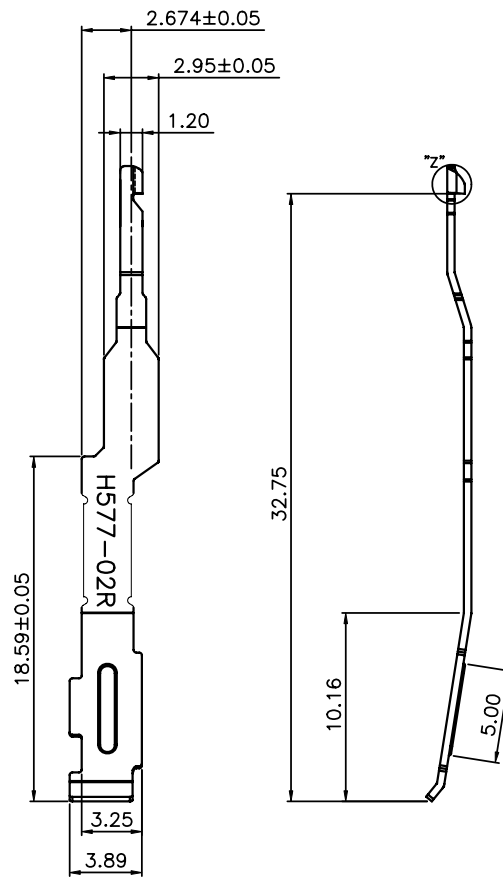

P/N:M22-0577-10002

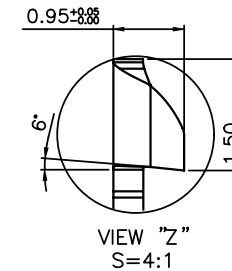

- NOTES  
 1.MATERIAL: STAINLESS SUS301; T=0.40mm  
 2.BURR: 0.10mm MAX.; DAMAGE: NA.  
 3.CAMBER: 20mm/m MAX.  
 4.DEFORMATION: 0.10mm MAX.  
 5.PLATING: NON-PLATING.  
 6.PART NO.

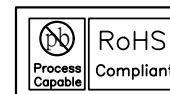
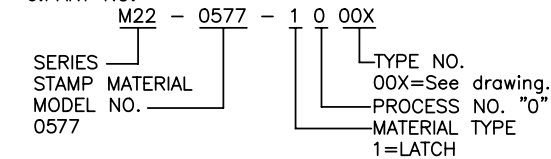

**WALTA** 華大電子股份有限公司  
 WALTA ELECTRONIC CO.,LTD.  
 TEL:886-2-26577778;FAX:886-2-26575659

D	E1202-028	△ X 0	整理圖面標注尺寸及公差配合	XJQ	2012/3/1	UNLESS OTHERWISE SPECIFIED TOLERANCE 尺寸公差 .X ±0.30 .XX ±0.20 ANG. ±1°00'	CHECKED 審核	DESIGNED 設計 JIMMY	TITLE 產品名稱 LATCH		
C	E0911-009	△ X 0	修改尺寸公差	LON	01/27/07'			APPROVED 承認		DRAWN 製圖 SAM	UNIT 單位 MM
B	EXXXX-XXX	△ X 0	新系統料號變更	LON	01/27/07'			SCALE 比例 1/1		PART NO. 產品料號 M22-0577-1000X	REV. 版本
REV. 版本	ECN NO. 設變號碼	MARK 記號	REVISIONS 設變內容	SIGN 修改	DATE 日期			DRAWN 尺寸 A4	DOC. NO. 文件編號 CUT-0577-006		