

RECOMMENDED P.C.B. LAYOUT (TOP VIEW)  
GENERAL TOLERANCE: ±0.05

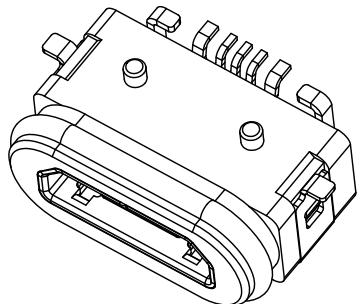

3D VIEW

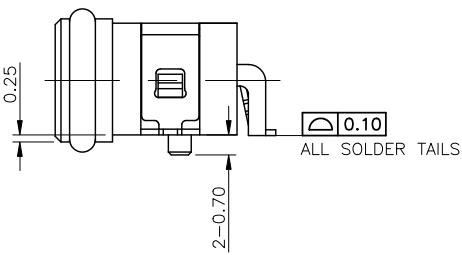
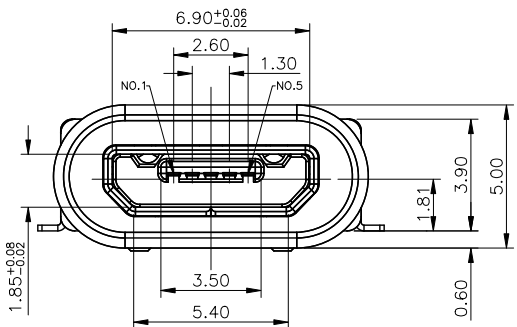

- SPECIFICATIONS:
- ELECTRICAL CHARACTERISTICS:
    - RATING: 3A(PIN1&5),0.5A(PIN2&3&4);
    - CONTACT RESISTANCE: 30 mΩ MAX.(INITIAL);
    - DIELECTRIC WITHSTANDING: 500V AC MIN.;
    - INSULATION RESISTANCE: 1000MΩ MIN.;
  - DURABILITY: 10,000 CYCLES MIN.;
  - INSERTION FORCE: 3.5Kgf (35N) Max.;
  - EXTRACTION FORCE: 0.8Kgf (8N) Min.;
  - WATER PROOFNESS: THIS PRODUCT IS BASED ON IPX8.
  - PLUG INTERFACE DIMENSIONS COMFORM TO USB2.0 SPEC.
  - PACKAGING: TAPE & REEL.

8. PART NO. U 03 - C 113 - 005 01

SERIES ———— TYPE NO.  
 USB Connector ———— 01=Type 1  
 CONN TYPE NO. ———— CONTACT NUMBER  
 03=type 3 ———— 005=5 position  
 FORM OF FACTORY ———— FACTORY CODE  
 C=Connector of factory

Contact Number	Signal Name	Remarks
1#	VBUS	Power
2#	D-	Date-
3#	D+	Date+
4#	ID	Reserve or Gound
5#	GND	Gound

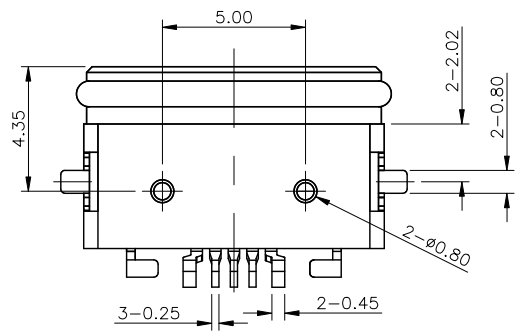

NO.	DESCRIPTION	QTY	MATERIAL	REMARK
⑦	Oval ring	1	Rubber	Black
⑥	Glue	1	-----	Black
⑤	U-shaped frame	1	Copper alloy or stainless	Nickel plated
④	Inner shell	1	Copper alloy or stainless	Nickel plated
③	Terminal	5	Copper alloy, 0.15t	Gold Plated On Contact Area.
②	Outer shell	1	High temperature thermoplastic	Black
①	Body	1	High temperature thermoplastic	Black



華大電子股份有限公司  
 WALTA ELECTRONIC CO.,LTD.  
 TEL:886-2-26577778;FAX:886-2-26575659

REV. 版本	ECN NO. 設變號碼	MARK 記號	REVISIONS 設變內容	SIGN 修改	DATE 日期	UNLESS OTHERWISE SPECIFIED TOLERANCE 尺寸公差	CHECKED 審核	DESIGNED 設計	SCALE 比例	TITLE 產品名稱	PART NO. 產品料號	REV. 版本
A	EXXXX-XXX	X 0	-	zhijun	2023/10/13	X. ±0.50 .X ±0.30 .XX ±0.20 ANG. ±5°0'	zhijun	2023/10/13	1/1	MICRO USB 2.0 B TYPE RECEPTACLE CUSTOMER DRAWING	U03-C113-00501	A