

ITEM 項目	PARTS NAME 零件名稱	Q'TY 數量	MATERIAL 材質	FINISH/REMARK 處理/備註
1	SHELL	1	SUS301	Ni:30u"
2	HOUSING	1	LCP E130i+30%G/F	(Black)UL94V-0
3	GND SPRING	2	SUS304	Ni:30u"
4	Insert molding	2	LCP E130i+30%G/F	(Black)UL94V-0
5	CONTACT	22	C7025	Contact area: Au:30u", Solder tails: Tin100u", Ni:30u"
6	LATCH	1	SUS301	Ni:30u"; Solder tails Tin:80U"
7	CAP	1	LCP	(Black)UL94V-0

Pin Number	host	device	Pin Number	host	device
Pin A1	GND	GND	Pin B12	GND	GND
Pin A2	SSTxp1	SSTxp1	Pin B11	SSRxp1	SSRxp1
Pin A3	SSTxn1	SSTxn1	Pin B10	SSRxn1	SSRxn1
Pin A4	VBUS	VBUS	Pin B9	VBUS	VBUS
Pin A5	CC	CC	Pin B8	SBU2	SBU2
Pin A6	DP1	DP1	Pin B7		
Pin A7	DN1	DN1	Pin B6		
Pin A8	SBU1	SBU1	Pin B5	Vconn	Vconn
Pin A9	VBUS	VBUS	Pin B4	VBUS	VBUS
Pin A10	SSRxn2	SSRxn2	Pin B3	SSTxn2	SSTxn2
Pin A11	SSRxp2	SSRxp2	Pin B2	SSTxp2	SSTxp2
Pin A12	GND	GND	Pin B1	GND	GND

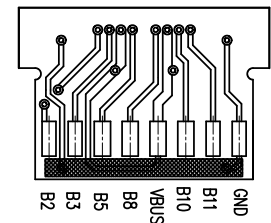
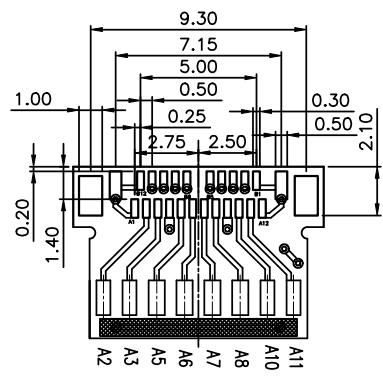
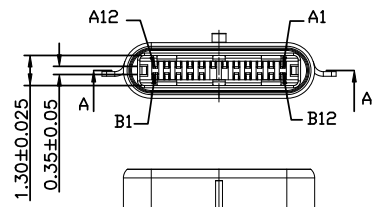
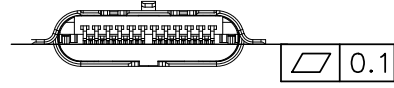
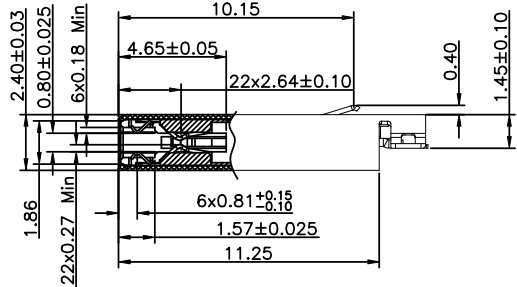
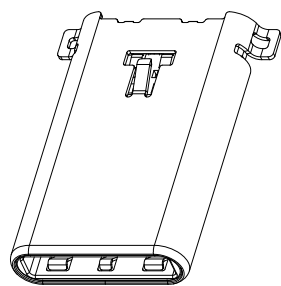
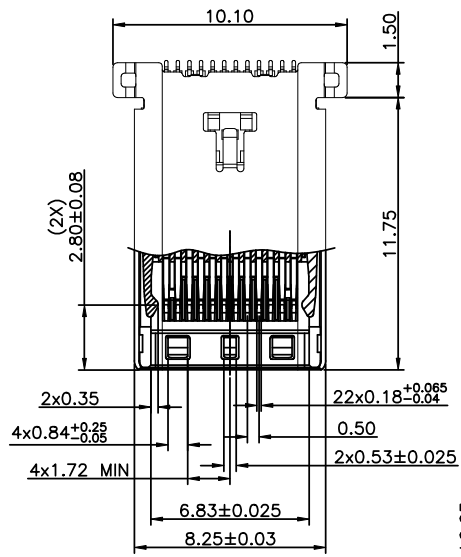

SPECIFICATION
MATERIAL
 See drawing
STANDARD DATA
 Rating current:
 5.0A for VBUS (i.e., pins A4, A9, B4, B9)
 1.25A for Vconn and GND (i.e., pins B5, A1, A12, B1, B12)
 0.25A for all the other contacts.
 Operating temperature: -10°C ~ +60°C
 Storage temperature: -20°C ~ +85°C
ELECTRICAL
 Insulator resistance: 100Mohms Min.
 Withstanding voltage: 100 VAC / minute
 Contact resistance: initial 40mohms Max;
 after 50mohms Max.

MECHANICAL
 Mating force: 5~20N
 Unmating force : Initial 8~20N
 After 10000 cycles 6~20N
 Durability: 10000 cycles Min.
 PART NO.

U 03 - C 085 - 022 001

SERIES U
 USB Connector
 CONN TYPE NO. 03=type03
 FORM OF FACTORY C=Connector of factory
 TYPE NO. 01=Type 01
 CONTACT NUMBER 022= 22 position
 FACTORY CODE 001

RECOMMENDED P.C.B LAYOUT
 TOP VIEW (TOLERANCE ±0.05mm)



WALTA 華大電子股份有限公司
 WALTA ELECTRONIC CO.,LTD.
 TEL:886-2-26577778; FAX:886-2-26575659

REV. 版本	ECN NO. 設變號碼	MARK 記號	REVISIONS 設變內容	SIGN 修改	DATE 日期	UNLESS OTHERWISE SPECIFIED TOLERANCE 尺寸公差	CHECKED 審核	DESIGNED 設計	UNIT 單位	TITLE 產品名稱
A	EXXXX-XXX	△ X 0				X. ±0.50 .X ±0.25 .XX ±0.15 .XXX ±0.10 ANG. ±2*0.0'		Lonlon 2019/06/04	MM	USB3.2 TYPE-C PLUG SMT TYPE
							APPROVED 承認	DRAWN 製圖 Lonlon 2019/06/04	SCALE 比例 1/1 SIZE 尺寸 A4	PART NO. 產品料號 U03-C085-02201 DOC. NO. 文件編號 CUT-C085-001

ITEM 項目	PARTS NAME 零件名稱	QTY 數量	MATERIAL 材質	FINISH/REMARK 處理/備註
1	SHELL	1	SUS301	Ni:30u"
2	HOUSING	1	LCP E130I+30%G/F	(Black)UL94V-0
3	GND SPRING	2	SUS304	Ni:30u"
4	Insert molding	2	LCP E130I+30%G/F	(Black)UL94V-0
5	CONTACT	22	C7025	Contact area: Au:30u", Solder tails: Tin100u", Ni:30u"
6	LATCH	1	SUS301	Ni:30u", Solder tails Tin:80u"
7	CAP	1	LCP	(Black)UL94V-0

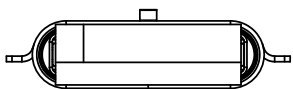
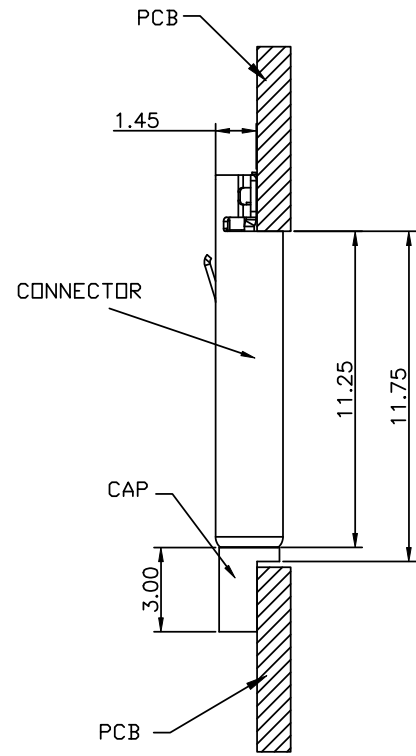
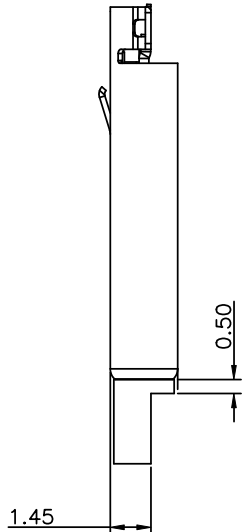
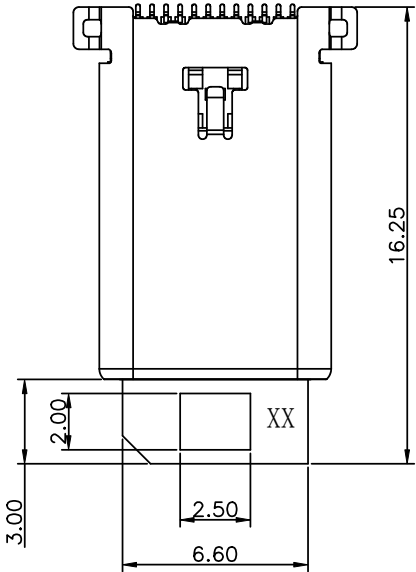
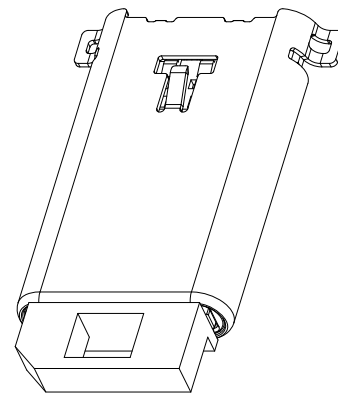

SPECIFICATION

MATERIAL
See drawing
STANDARD DATA
Rating current:
5.0A for VBUS (i.e., pins A4, A9, B4, B9)
1.25A for Vconn and GND (i.e., pins B5, A1, A12, B1, B12)
0.25A for all the other contacts.
Operating temperature: -10°C ~ +60°C
Storage temperature: -20°C ~ +85°C
ELECTRICAL
Insulator resistance: 100Mohms Min.
Withstanding voltage: 100 VAC / minute
Contact resistance: initial 40mohms Max;
after 50mohms Max.

MECHANICAL

Mating force: 5~20N
Unmating force : Initial 8~20N
After 10000 cycles 6~20N
Durability: 10000 cycles Min.
PART NO.

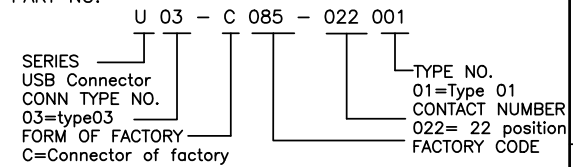

WALTA 華大電子股份有限公司
WALTA ELECTRONIC CO.,LTD.
TEL:886-2-26577778; FAX:886-2-26575659

REV. 版本	ECN NO. 設變號碼	MARK 記號	REVISIONS 設變內容	SIGN 修改	DATE 日期	UNLESS OTHERWISE SPECIFIED TOLERANCE 尺寸公差	CHECKED 審核	DESIGNED 設計	UNIT 單位	TITLE 產品名稱	SCALE 比例	PART NO. 產品料號	REV. 版本
A	EXXXX-XXX	△ X 0				X. ±0.50 .X ±0.25 .XX ±0.15 .XXX ±0.10 ANG. ±2'00"		Lonlon	MM	USB3.2 TYPE-C PLUG SMT TYPE	1/1	U03-C085-02201	2/3
							APPROVED 承認	Lonlon	A4	CUT-C085-001			A
								2019/06/04					

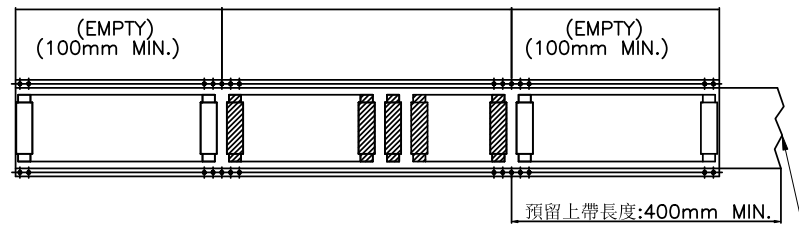
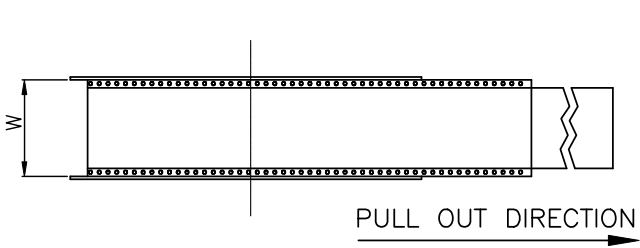

ITEM 項目	PARTS NAME 零件名稱	FINISH/REMARK 處理/備註
1	I/O CONNECTOR	9600 PCS/BOX(REFERENCE)
2	BOX	8 REEL/BOX
3	WATERPROOF BAG	1 PCS
4	REEL	--
5	COVER TAPE	(COLOR:TRANSPARENT)
6	CARRIER TAPE	1200 PCS/REEL(REFERENCE)
7	LABEL	批號標籤

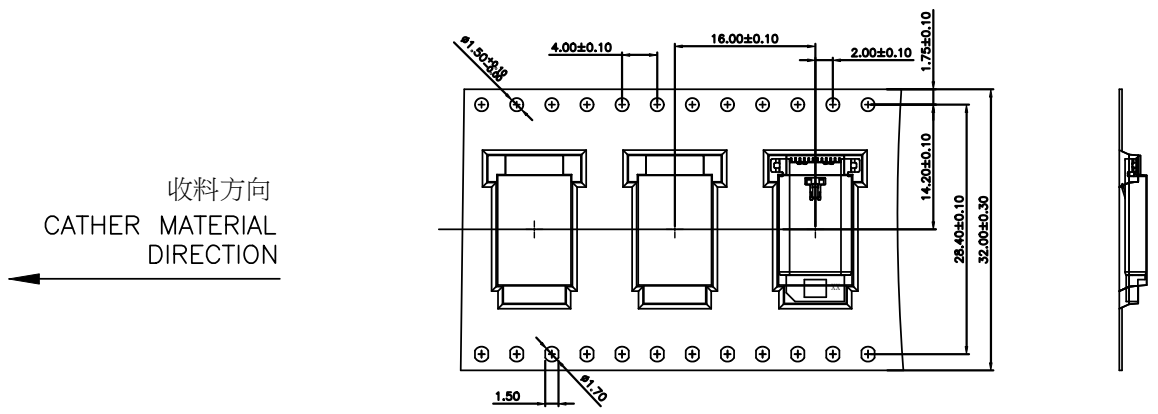
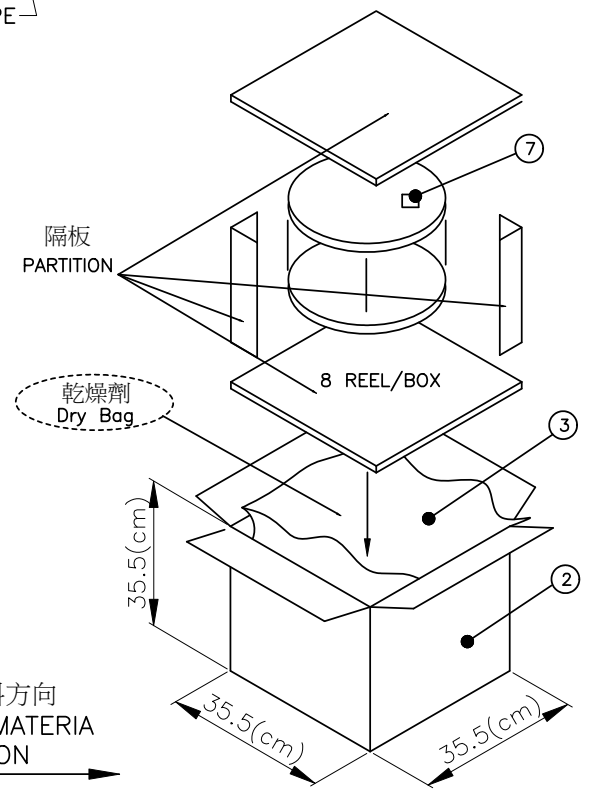
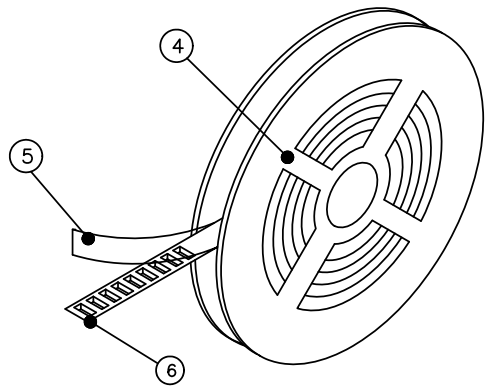
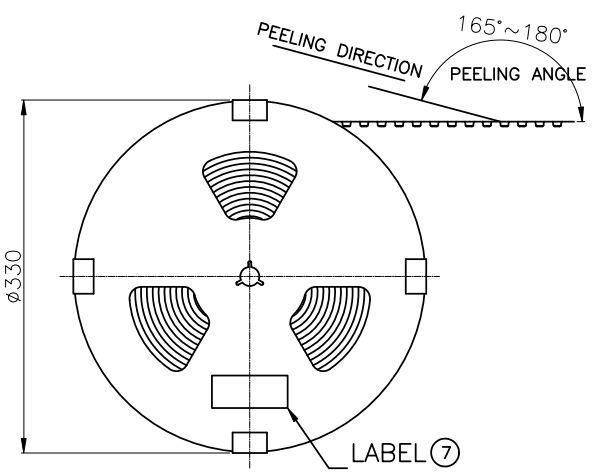

客戶放料方向
INPUT MATERIA
DIRECTION

- NOTES
- 1.MATERIAL: PS (Color: 透明)
 - 2.DEFORMATION(變形)&DAMAGE(損壞): NA.(不可)
 - 3.All dimensions meet EIA-481-C requirements.

TAPE REEL成品擺放方向

RoHS
Compliant

WALTA

華大電子股份有限公司
WALTA ELECTRONIC CO.,LTD.
TEL:886-2-26577778;FAX:886-2-26575659

REV. 版本	ECN NO. 設變號碼	MARK 記號	REVISIONS 設變內容	SIGN 修改	DATE 日期	UNLESS OTHERWISE SPECIFIED TOLERANCE 尺寸公差	CHECKED 審核	DESIGNED 設計	UNIT 單位	TITLE 產品名稱	REV. 版本
A	EXXXX-XXX	△ X 0				X. ±0.50 .X ±0.30 .XX ±0.20 ANG. ±5'00"		London 2019/06/04	MM	USB3.2 TYPE-C PLUG SMT TYPE	3/3
							APPROVED 承認	London 2019/06/04	SCALE 比例 1/1	PART NO. 產品料號 U03-C085-02201	
									SIZE 尺寸 A4	DOC. NO. 文件編號 CUT-C085-001	A