

PIN ASSIGNMENT

PIN NO.	1	2	3	4
SINGAL NAME	GND	D+	D-	VBUS

ITEM 項目	PARTS NAME 零件名稱	Q'TY 數量	MATERIAL 材質	FINISH/REMARK 處理/備註
1	HOUSING	1	SYNTHETIC RESIN	Black
2	CONTACT	4	COPPER ALLOY	1u"Gold on contact area 80u" Tin on solder tails,base Ni:50u"
3	SHELL	1	STAINLESS	Ni:50u"
4	COVER	1	SYNTHETIC RESIN	Black

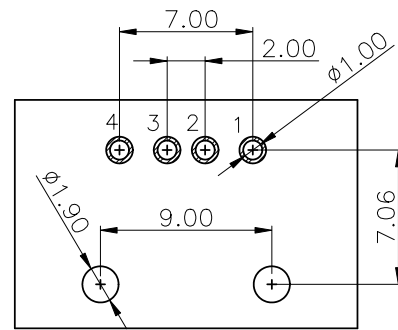
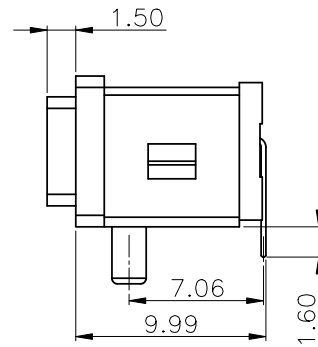
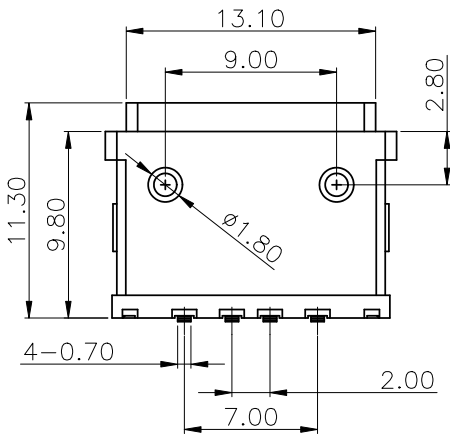
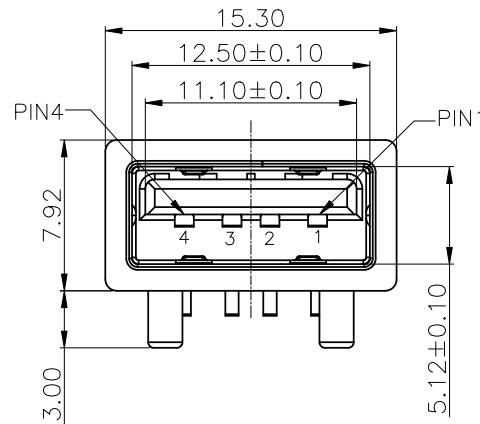
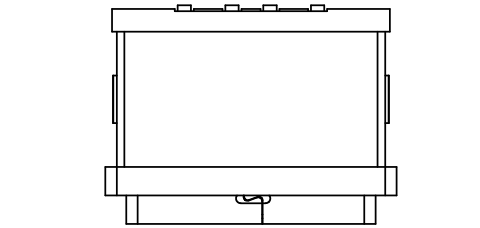

RECOMMENDED PCB LAYOUT(TOP VIEW)
 DEFAULT TOLERANCE+/-0.05
 THICKNESS T=1.0mm

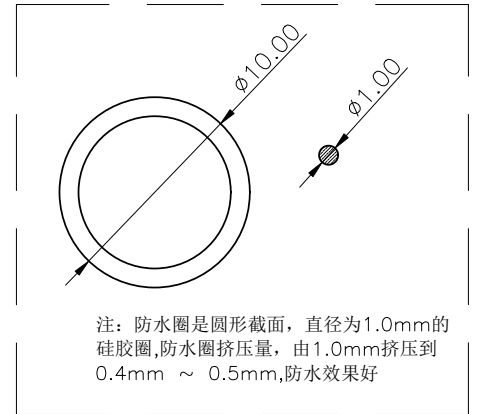

注：防水圈是圓形截面，直徑為1.0mm的
 硅膠圈，防水圈擠壓量，由1.0mm擠壓到
 0.4mm ~ 0.5mm,防水效果好

SPECIFICATION

MATERIAL

See drawing
 STANDARD DATA

Rating current:3.0A

Operating temperature: -0°C ~ +50°C

Storage temperature: -20°C ~ +60°C

ELECTRICAL

Insulator resistance: 1000Mohms Min.

Withstanding voltage: 500 VAC / minute

Contact resistance: 30mohms Max.

MECHANICAL

Mating force: 8N~35N

Unmating force: 8N~35N

Durability: 1500 cycles

Salt spray: Salt water density of 5%,temperature of 35°C,
 time 24hours

PART NO.

SERIES U 02 - C 113 - 004 01 TYPE NO.
 USB Connector 01=Type 1
 CONN TYPE NO. CONTACT NUMBER
 02=type 2 004=4 position
 FORM OF FACTORY FACTORY CODE
 C=Connector of factory

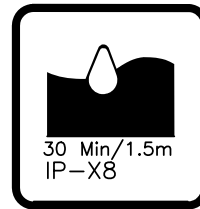

WALTA 華大電子股份有限公司
 WALTA ELECTRONIC CO.,LTD.
 TEL:886-2-26577778;FAX:886-2-26575659

REV. 版本	ECN NO. 設變號碼	MARK 記號	REVISIONS 設變內容	SIGN 修改	DATE 日期	UNLESS OTHERWISE SPECIFIED TOLERANCE 尺寸公差	CHECKED 審核	DESIGNED 設計	SCALE 比例	TITLE 產品名稱
A	E2111-001	X 0		CR	2021/11/3	X. ±0.50 .X ±0.30 .XX ±0.20 ANG. ±5°0'		CR 2021/11/3	MM 1/1	USB 2.0 防水母座
							APPROVED 承認	DRAWN 製圖	SIZE 尺寸	PART NO. 產品料號 DOC. NO. 文件編號
								CR 2021/11/3	A4	U02-C113-00401 CUT-C113-002