

SECTION A-A

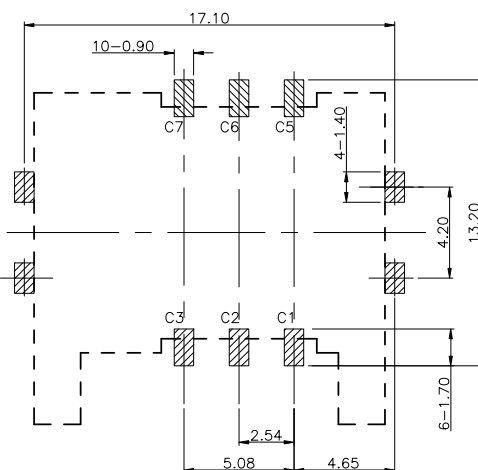

RECOMMENDED PCB MOUNTING PATTERN

PIN NO.	PIN NAME
C 1	Supply Voltage Vcc
C 2	Reset (RST)
C 3	Clock(CLK)
C 4	N/A
C 5	Ground
C 6	Programming Voltage Vpp
C 7	I/O
C 8	N/A

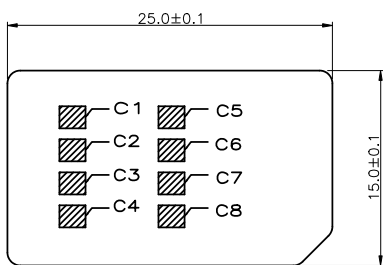

REFERENCE SIM CARD PLUG

ITEM 項目	PARTS NAME 零件名稱	Q'TY 數量	MATERIAL 材質	FINISH/REMARK 處理/備註
1	HOUSING	1	SYNTHETIC RESIN	Black
2	CONTACT	6	COPPER ALLOY	Gold Flash on contact area Gold Flash on solder tails, base Nickel: 30u"
3	SHELL	1	STAINLESS	Ni:50u",Gold flash over all

SPECIFICATION

CURRENT RATING: 1A MAX./ (1PIN)
 VOLTAGE RATING: 12V AC/DC
 DIELECTRIC WITHSTANDING: 500V AC /MINUTE
 CONTACT RESISTANCE: 60mΩ Max.
 INSULATION RESISTANCE: 1000MΩ Min.
 OPERATING TEMPERATURE: -25°C to +70°C
 DURABILITY: 500 CYCLES MIN.
 CONTACT RETENTION: 2.45N(0.25kgf)MIN.
 INSERTION FORCE: 10N(1.02kgf)MAX.
 WITHDRAWAL FORCE: 2N(0.2kgf)MAX.

PART NO.

SD Connector
 CONN TYPE NO.
 FORM OF FACTORY
 C=Connector of factory

S 06 - C 088 - 006 01

TYPE NO.
 01=Type 1
 CONTACT NUMBER
 006=6 position
 FACTORY CODE



WALTA 華大電子股份有限公司
 WALTA ELECTRONIC CO.,LTD.
 TEL:886-2-26577778;FAX:886-2-26575659

REV. 版本	ECN NO. 設變號碼	MARK 記號	REVISIONS 設變內容	SIGN 修改	DATE 日期	UNLESS OTHERWISE SPECIFIED TOLERANCE 尺寸公差 X. ±0.50 .X ±0.30 .XX ±0.20 ANG. ±5°00'	CHECKED 審核 APPROVED 承認	DESIGNED 設計 2021/5/14	DRAWN 製圖 CR 2021/5/14	TITLE 產品名稱 SIM Push-Pull Type 6Pin H:1.9mm UNIT 單位 MM SCALE 比例 1/1 SIZE 尺寸 A4	PART NO. 產品料號 S06-C088-00601	REV. 版本 1/2
A	E2105-004	△ X 0	-	CR	2021/5/14							A

