

NOTES:  
 1.MATERIAL:  
 HOUSING: LCP, UL94V-0, Black  
 SLIDE: LCP, UL94V-0, Black  
 CONTACT: PHOSPHOR BRONZE (C5191)  
 SHELL: STAINLESS (SUS304)  
 SPRING: SWP-B  
 CRANK-AXLE: STAINLESS (SUS304)

2.FINISH:  
 CONTACT:  
 CONTACT AREA: 1u" GOLD PLATED  
 SOLDER AREA: 80u" TIN PLATED  
 UNDER PLATING: 30u" NICKEL PLATED  
 SHELL:  
 SOLDER AREA: G/F GOLD PLATED  
 UNDER PLATING: 30u" NICKEL PLATED.

3.SPECIFICATION:  
 CURRENT RATING: 0.5A / (1PIN)  
 VOLTAGE RATING: 50V AC/DC  
 DIELECTRIC WITHSTANDING: 500V AC FOR 1 MINUTE  
 CONTACT RESISTANCE: 100mΩ Max.  
 INSULATION RESISTANCE: 1000MΩ Min  
 OPERATING TEMPERATURE: -40°C to +85°C  
 DURABILITY: 5000 CYCLES MIN.  
 CONTACT RETENTION: 2.5N MIN.  
 INSERTION FORCE: 10N MAX.  
 WITHDRAWAL FORCE: 2N

4.PART NO.  
 S 05 - C 088 - 006 01  
 SERIES SD Connector TYPE NO. 01=Type 1  
 CONN TYPE NO. CONTACT NUMBER  
 05=type 5 006=6 position  
 FORM OF FACTORY FACTORY CODE  
 C=Connector of factory

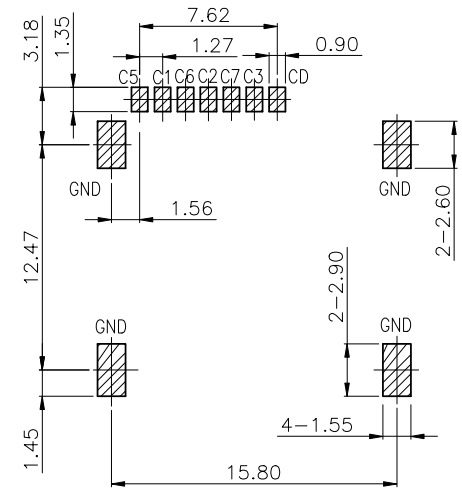
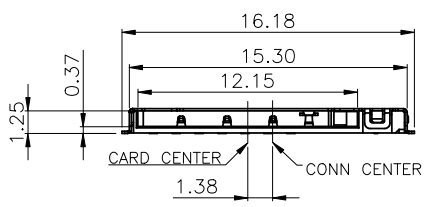

RECOMMENDED PCB LAYOUT  
 GENERAL TOLERANCE ±0.05

ELECTRIC FUNCTION	DETECT SWITCH
WITHOUT CARD	CLOSED
CARD INSERTED	OPEN

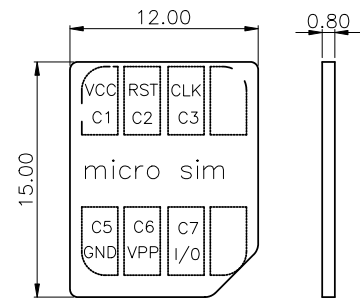
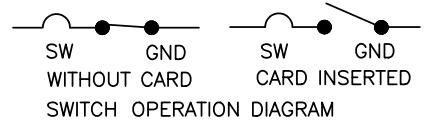

SIM pin Assignment	
PIN#	Name
C1	VCC
C2	RST
C3	CLK
C5	GND
C6	VPP
C7	I/O



**WALTA** 華大電子股份有限公司  
 WALTA ELECTRONIC CO.,LTD.  
 TEL:886-2-26577778;FAX:886-2-26575659

REV. 版本	ECN NO. 設變號碼	MARK 記號	REVISIONS 設變內容	SIGN 修改	DATE 日期	UNLESS OTHERWISE SPECIFIED TOLERANCE 尺寸公差	CHECKED 審核	DESIGNED 設計	SCALE 比例	TITLE 產品名稱	PART NO. 產品料號	REV. 版本
A	E2003-003	△ X 0	-	CR	2020/3/26	X. ±0.50 .X ±0.30 .XX ±0.20 ANG. ±5°00'	APPROVED 承認	CR 2020/3/26	1/1	Micro SIM Push-Push Type 6Pin W/SW H=1.35mm	S05-C088-00601	A
1	2	3	4	5	6	7	8	9	10			

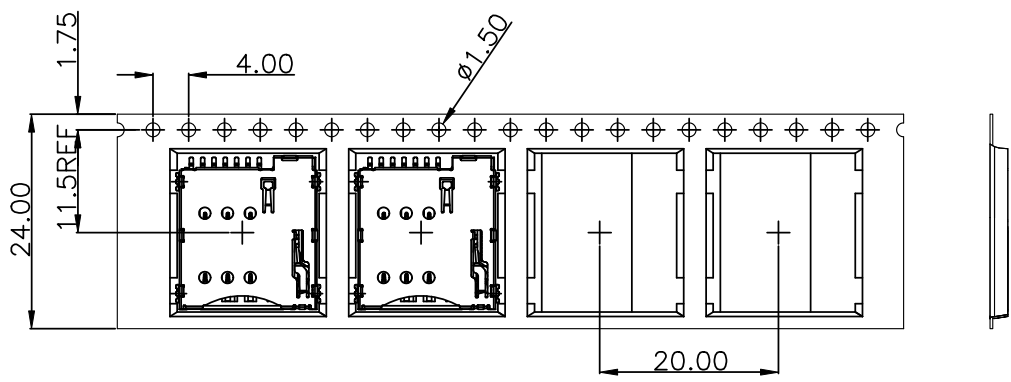
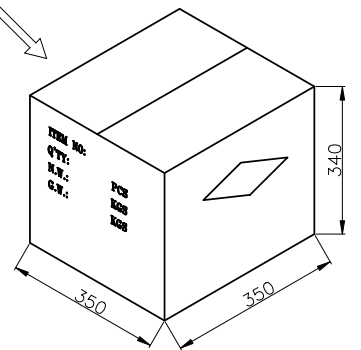
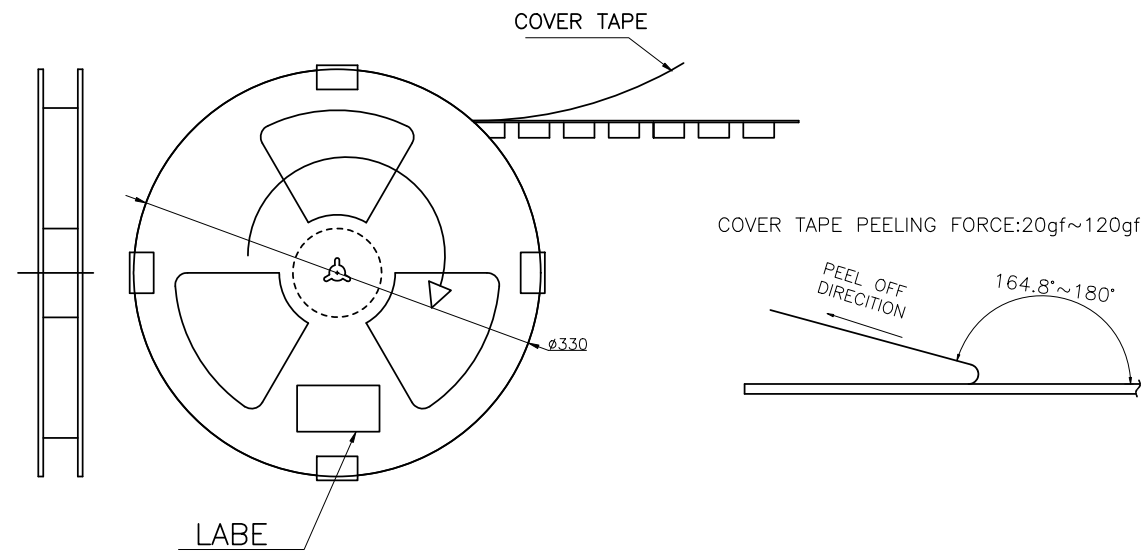
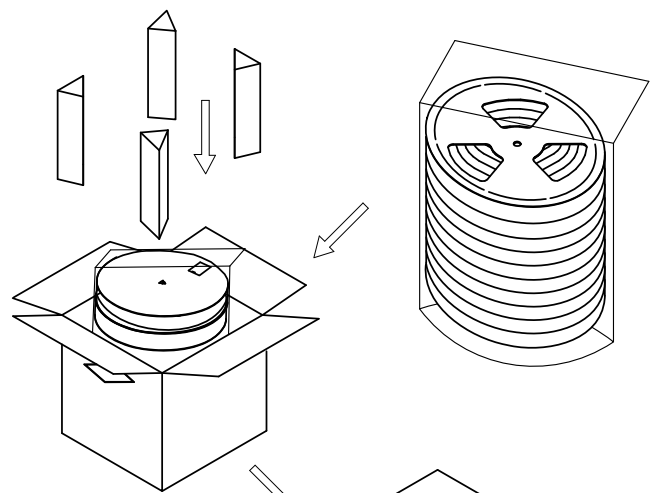
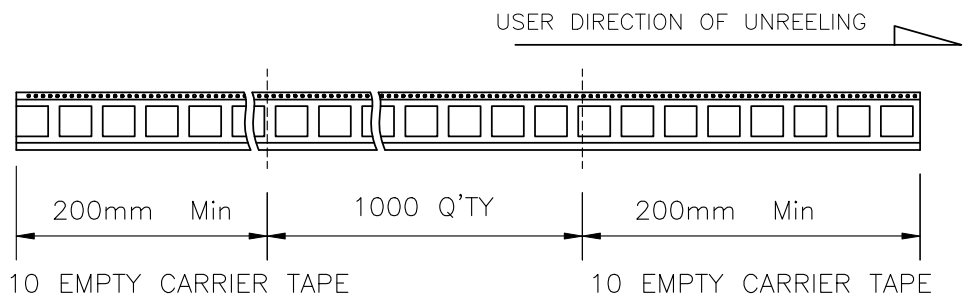

- NOTES:
1. PACKING STYLE: 1,000 PCS/REEL  
10,000 PCS/OUTER CARTON
  2. MATERIAL: CARRIER TAPE: PS BLACK  
COVER TAPE: PET FILM  
REEL: PLASTIC
  3. PEEL STRENGTH OF COVER TAPE: 20~80g(PEEL SPEED 300mm/MINUTE)
  4. CARTON SIZE: 350x350x340mm
  5. G/W: 10.1 Kg , N/W: 4.54 Kg



**WALTA** 華大電子股份有限公司  
WALTA ELECTRONIC CO.,LTD.  
TEL:886-2-26577778;FAX.886-2-26575659

REV. 版本	ECN NO. 設變號碼	MARK 記號	REVISIONS 設變內容	SIGN 修改	DATE 日期
A	E2003-003	X 0		CR	2020/3/26

UNLESS OTHERWISE SPECIFIED TOLERANCE 尺寸公差	CHECKED 審核	DESIGNED 設計
X. ±0.50		CR 2020/3/26
.X ±0.30	APPROVED 承認	DRAWN 製圖
.XX ±0.20		CR 2020/3/26
ANG. ±5°00'		

TITLE 產品名稱	Micro SIM Push-Push Type 6Pin W/SW H=1.35mm 2/2	
UNIT 單位	MM	
SCALE 比例	1/1	
PART NO. 產品料號	S05-C088-00601	REV. 版本
DOC. NO. 文件編號	CUT-C088-006	A