

ITEM 項目	PARTS NAME 零件名稱	Q'TY 數量	MATERIAL 材質	FINISH/REMARK 處理/備註
1	CONNECTOR	1	HOUSING:PA9T GP2300T	(Black) UL 94V-0
			CONTACT:C7025,T=0.20	Contact area:1u"MIN. Solder tails:Tin80u", Ni:80u"
			SHELL:SUS316L,T=0.15	50u" MIN. NICKEL OVER ALL.
			LATCH:SUS301,T=0.25mm	40u" MIN. NICKEL OVER ALL. GOLD FLASH ON Solder tails.
2	PCB	1	FR4	(Black) UL 94V-0 2-LAYER,INK-RED,MARK-WHITE

A12	A11	A10	A9	A8	A7	A6	A5	A4	A3	A2	A1
GND			Vbus		D-	D+	CC	Vbus			GND
GND			Vbus	Vconn				Vbus			GND
B1	B2	B3	B4	B5	B6	B7	B8	B9	B10	B11	B12

PCB PIN DESCRIPTION:

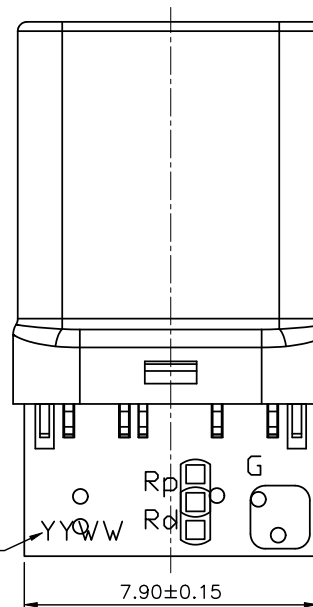
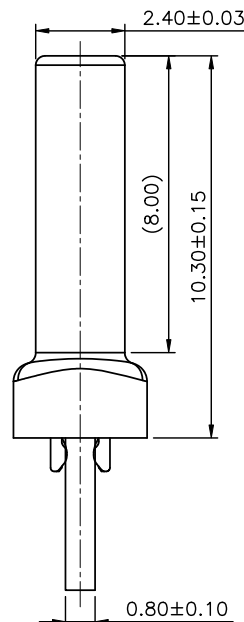
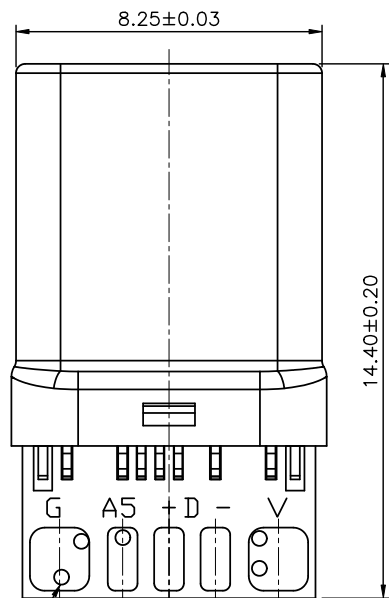
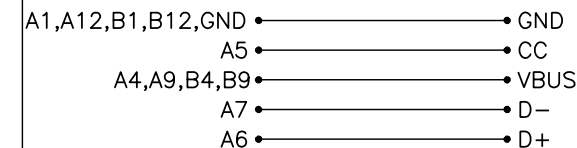

PAD SOLDER PASTE
HEIGHT 0.15 MIN.

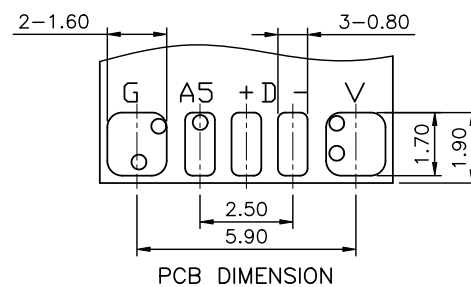
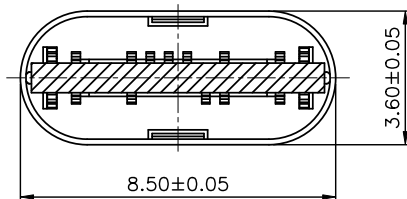

NOTES

- MATERIAL: See drawing
- STANDARD DATA
 - Rating current: 5.0A for VBUS ;
1.25A for Vconn and GND ;
0.25A for all the other contacts.
- ELECTRICAL
 - Insulator resistance: 100M ohms Min.
 - Withstanding voltage: 100 VAC / minute
 - Contact resistance: initial 40mohms Max.
after 50mohms Max.
- MECHANICAL
 - Mating force: 5~20N
 - Unmating force : Initial 8~20N
After 10000cycles 6~20N
 - Durability: 10000 cycles Min.
- PACKING: 100pcs/tray (reference)
- PART NO.

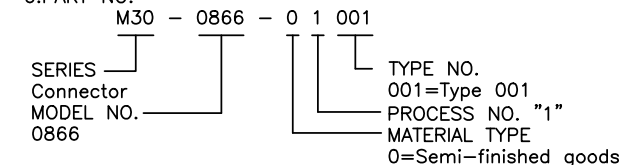

華大電子股份有限公司
WALTA ELECTRONIC CO.,LTD.
TEL:886-2-26577778;FAX:886-2-26575659

REV. 版本	ECN NO. 設變號碼	MARK 記號	REVISIONS 設變內容	SIGN 修改	DATE 日期	UNLESS OTHERWISE SPECIFIED TOLERANCE 尺寸公差	CHECKED 審核	DESIGNED 設計	TITLE 產品名稱	UNIT 單位	SCALE 比例	PART NO. 產品料號	SHEET 頁碼
A	E2210-001	X 0	新開	Lonlon	2022/9/27	X. ±0.50 .X ±0.25 .XX ±0.15 .XXX ±0.10 ANG. ±2'00'	APPROVED 承認	London 2022/9/27	USB TYPE-C PLUG (C TO C)	MM	1/1	M30-0866-01001	1/2
								London 2022/9/27	CUT-0866-007	A4			A

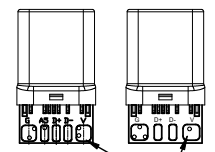
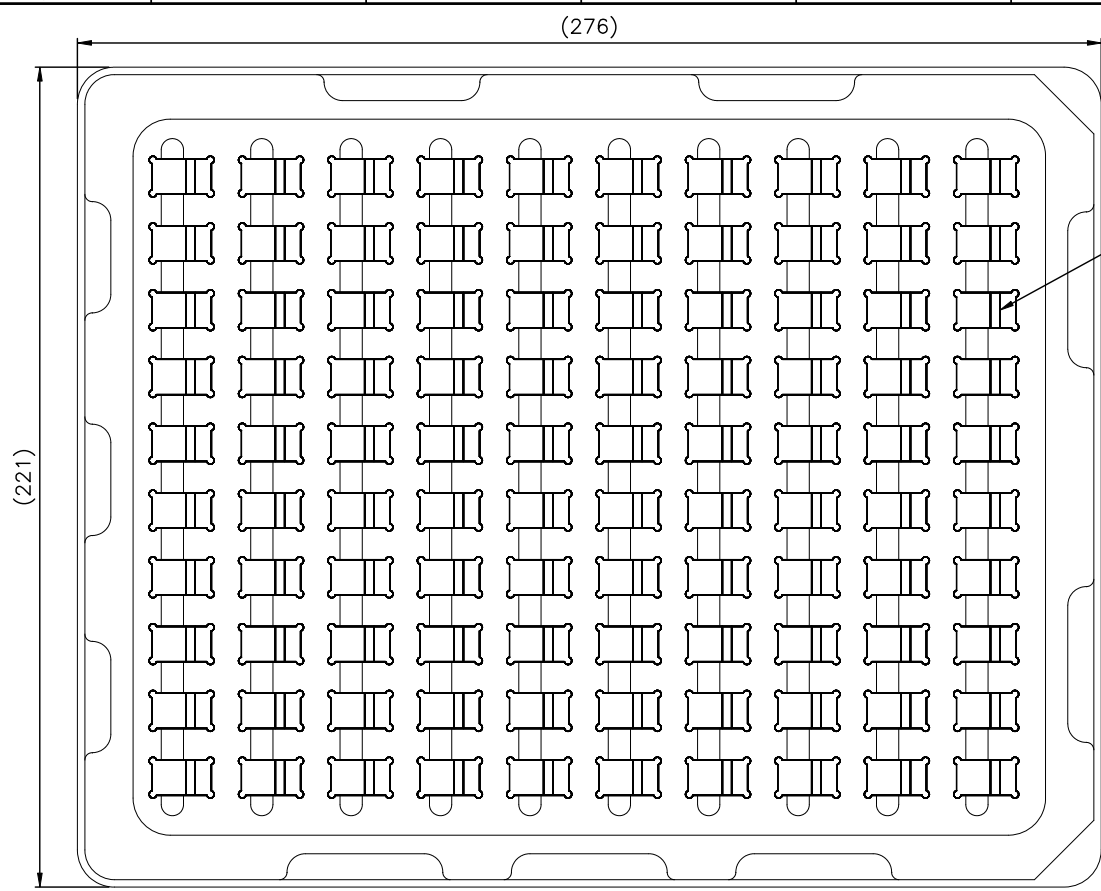

100PCS/TRAY 焊盤面

擺入吸塑盒內時,有電子元件一面朝下,焊盤朝上。

NOTES:

1. 100PCS/TRAY,50TRAY/BUNDLE,2BUNDLE/CARTON,10000PCS/CARTON.
100PCS/盤, 50盤/捆, 2捆/箱, 10000PCS/箱。
2. OUTSIDE THE BOX MUST BE AFFIXED WITH A LABEL, INDICATING THE ITEM NUMBER, NAME, BATCH NUMBER, DATE, QUANTITY.
包裝盒外必須貼有標籤, 標明貨號、名稱、批號、日期、數量。

TRAY (COLOR: BLACK)

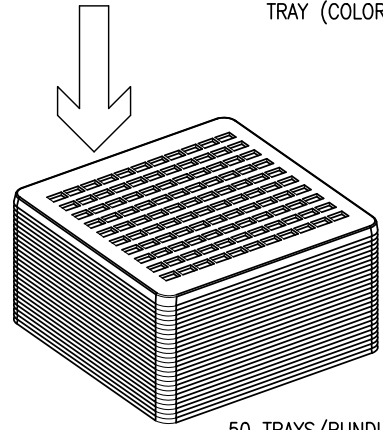

50 TRAYS/BUNDLE,
(PUT 1PCS EMPTY TRAY AT THE TOP)

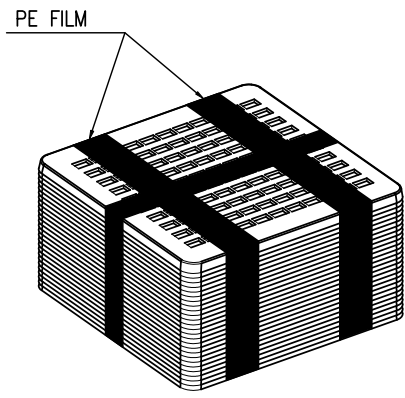

PE FILM

2BUNDLE/CARTON

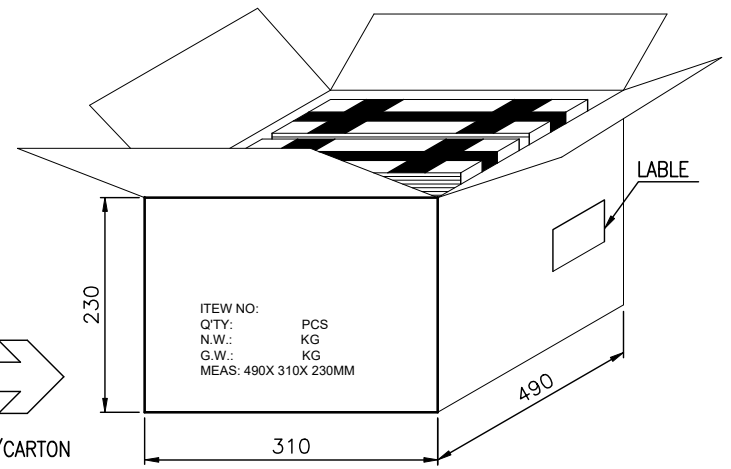

LABLE

ITEM NO:
QTY: PCS
N.W.: KG
G.W.: KG
MEAS: 490X 310X 230MM



WALTA 華大電子股份有限公司
WALTA ELECTRONIC CO.,LTD.
TEL:886-2-26577778;FAX:886-2-26575659

A		E2210-001	X 0	新開	Lonlon	2022/9/27	UNLESS OTHERWISE SPECIFIED TOLERANCE 尺寸公差 .X ±0.50 .X ±0.25 .XX ±0.15 .XXX ±0.10 ANG. ±2'00	CHECKED 審核 DESIGNED 設計 London 2022/9/27	UNIT 單位 MM	TITLE 產品名稱 USB TYPE-C PLUG 12PIN PACKAGING SPECIFICATIONS	
REV. 版本	ECN NO. 設變號碼	MARK 記號	REVISIONS 設變內容		SIGN 修改	DATE 日期	APPROVED 承認	DRAWN 製圖 London 2022/9/27	SCALE 比例 1/1	PART NO. 產品料號 M30-0866-0100X	SHEET 頁碼 2/2
1	2	3	4	5	6	7	8	9	10		

A