

ITEM 項目	PARTS NAME 零件名稱	Q'TY 數量	MATERIAL 材質	FINISH/REMARK 處理/備註
1	SHELL	1	SUS316L,T=0.15	50u" MIN. NICKEL OVER ALL.
2	HOUSING	1	PA9T GP2300T	(Black)UL 94V-0
3	LATCH	1	SUS301,T=0.25	50u" MIN. NICKEL OVER ALL. GOLD FLASH ON Solder tails.
4	CONTACT	24	C7025,T=0.20	Contact area:Au:1u"MIN. Solder tails:Tin:80u",Ni:50u"OVER ALL.
5	MOLDING	2	LCP E130i	(Black)UL 94V-0
6	CAP	1	LCP E130i	(Black)UL 94V-0

NOTES

- MATERIAL: See drawing
- STANDARD DATA
  - Rating current: 5.0A for VBUS ; 1.25A for Vconn and GND ; 0.25A for all the other contacts.
- ELECTRICAL
  - Insulator resistance: 100M ohms Min.
  - Withstanding voltage: 100 VAC / minute
  - Contact resistance: initial 40mohms Max. after 50mohms Max.
- MECHANICAL
  - Mating force: 5~20N
  - Unmating force : Initial 8~20N After 10000cycles 6~20N
  - Durability: 10000 cycles Min.
- PACKING: 100pcs/tray (reference)
- PART NO.

M30 - 0866 - 0 0 02

SERIES Connector MODEL NO. 0866

TYPE NO. 002=Type 002 PROCESS NO. "0" MATERIAL TYPE 0=Semi-finished goods

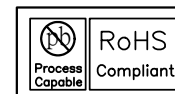

華大電子股份有限公司  
WALTA ELECTRONIC CO.,LTD.  
TEL:886-2-26577778;FAX:886-2-26575659

REV. 版本	ECN NO. 設變號碼	MARK 記號	REVISIONS 設變內容	SIGN 修改	DATE 日期
A	E2210-001	X 0	新增12PIN規格	Lonlon	2022/9/27

UNLESS OTHERWISE SPECIFIED TOLERANCE 尺寸公差	CHECKED 審核	DESIGNED 設計
X. ±0.50	Lonlon	2022/9/27
.X ±0.25	APPROVED 承認	DRAWN 製圖
.XX ±0.15		Lonlon
.XXX ±0.10		2022/9/27
ANG. ±2'00'		

TITLE 產品名稱	PART NO. 產品料號	DOC. NO. 文件編號
USB TYPE-C PLUG 12PIN <td>M30-0866-00002 <td>CUT-0866-003 </td></td>	M30-0866-00002 <td>CUT-0866-003 </td>	CUT-0866-003

UNIT 單位	SCALE 比例	SIZE 尺寸	SHEET 頁碼	REV. 版本
MM	1/1	A4	1/3	A

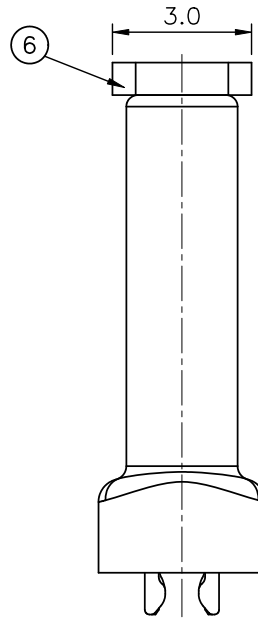
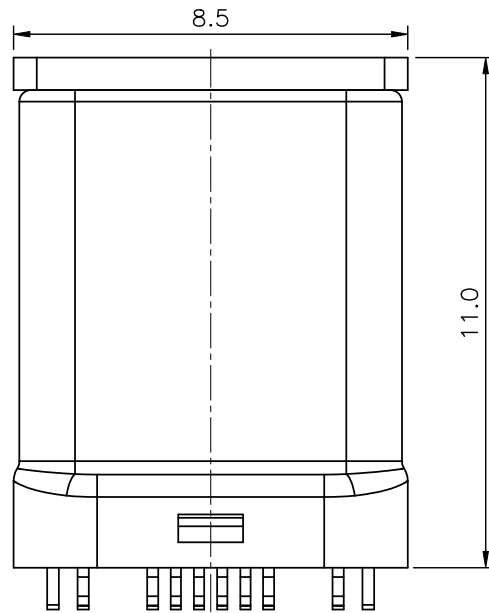

WITH CAP DRAWING

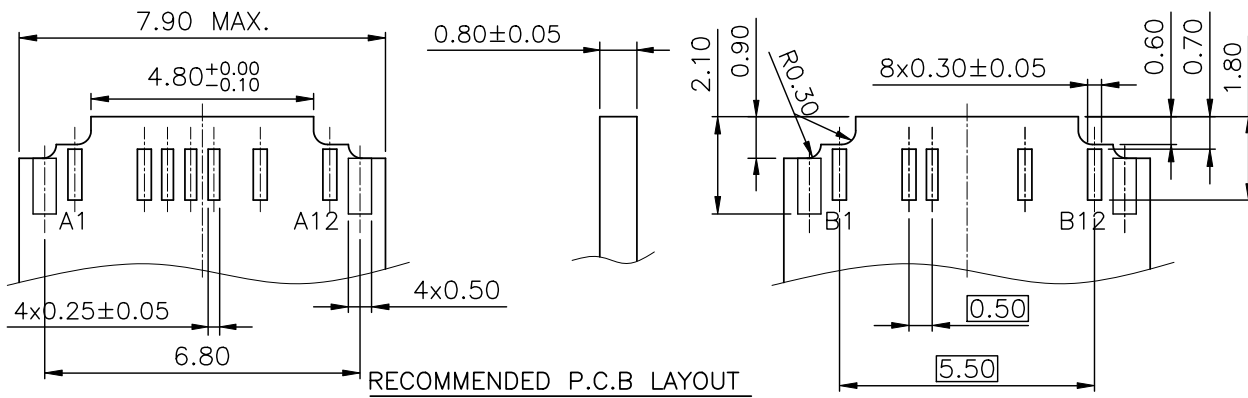

**RECOMMENDED P.C.B LAYOUT**  
ALL TOLERANCE  $\pm 0.05\text{mm}$

Pin Number	host	device	Pin Number	host	device
Pin A1	GND	GND	Pin B12	GND	GND
Pin A2	SSTxp1	SSTxp1	Pin B11	SSRxp1	SSRxp1
Pin A3	SSTxn1	SSTxn1	Pin B10	SSRxn1	SSRxn1
Pin A4	VBUS	VBUS	Pin B9	VBUS	VBUS
Pin A5	CC1	CC1	Pin B8	SBU2	SBU2
Pin A6	DP1	DP1	Pin B7		
Pin A7	DN1	DN1	Pin B6		
Pin A8	SBU1	SBU1	Pin B5	CC2	CC2
Pin A9	VBUS	VBUS	Pin B4	VBUS	VBUS
Pin A10	SSRxn2	SSRxn2	Pin B3	SSTxn2	SSTxn2
Pin A11	SSRxp2	SSRxp2	Pin B2	SSTxp2	SSTxp2
Pin A12	GND	GND	Pin B1	GND	GND

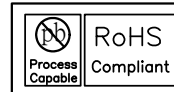

**WALTA** 華大電子股份有限公司  
WALTA ELECTRONIC CO.,LTD.  
TEL:886-2-26577778;FAX:886-2-26575659

REV. 版本	ECN NO. 設變號碼	MARK 記號	REVISIONS 設變內容	SIGN 修改	DATE 日期
A	E2210-001	X 0	新增12PIN規格	Lonlon	2022/9/27

UNLESS OTHERWISE SPECIFIED TOLERANCE 尺寸公差	CHECKED 審核	DESIGNED 設計
X. $\pm 0.50$		Lonlon
.X $\pm 0.25$		2022/9/27
.XX $\pm 0.15$	APPROVED 承認	
.XXX $\pm 0.10$		DRAWN 製圖
ANG. $\pm 2'00''$		Lonlon
		2022/9/27

TITLE 產品名稱	PART NO. 產品料號	SHEET 頁碼
USB TYPE-C PLUG 12PIN <td>M30-0866-00002 <td>2/3 </td></td>	M30-0866-00002 <td>2/3 </td>	2/3
UNIT 單位	DOC. NO. 文件編號	REV. 版本
MM	CUT-0866-003 <td>A</td>	A
SCALE 比例	SIZE 尺寸	
1/1	A4	

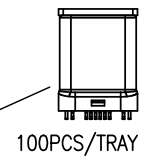
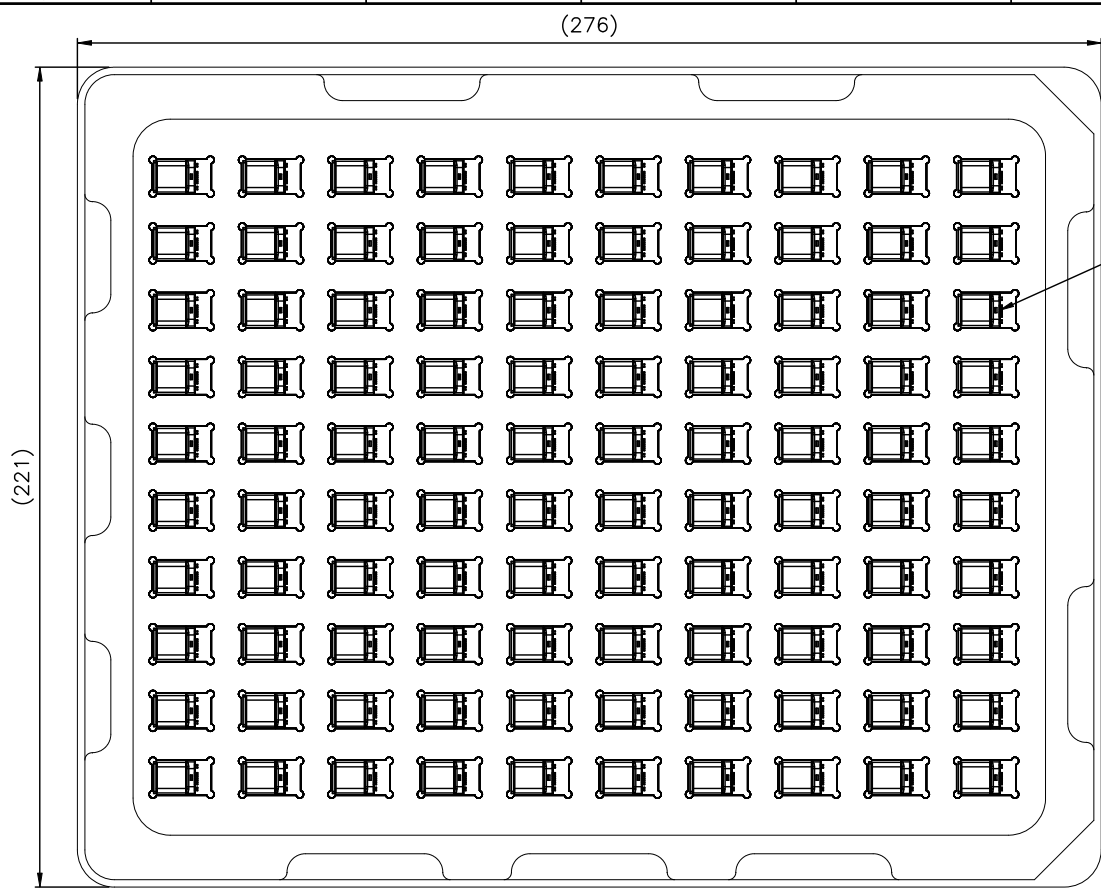

- NOTES:
- 100PCS/TRAY, 50TRAY/BUNDLE, 2BUNDLE/CARTON, 10000PCS/CARTON.  
100PCS/盤, 50盤/捆, 2捆/箱, 10000PCS/箱。
  - OUTSIDE THE BOX MUST BE AFFIXED WITH A LABEL, INDICATING THE ITEM NUMBER, NAME, BATCH NUMBER, DATE, QUANTITY.  
包裝盒外必須貼有標籤, 標明貨號、名稱、批號、日期、數量。

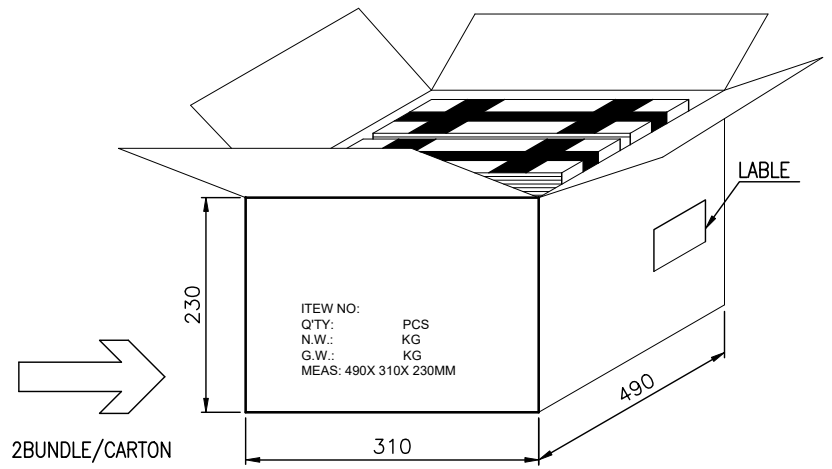
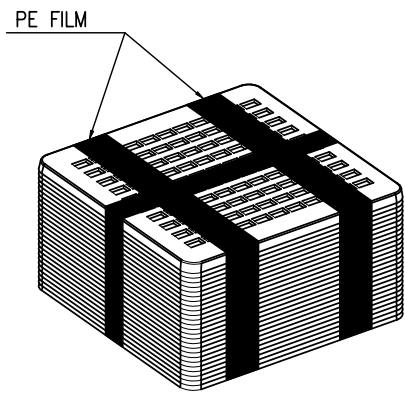
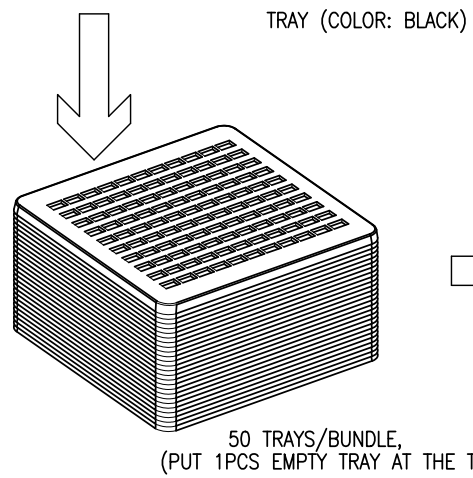

**WALTA** 華大電子股份有限公司  
WALTA ELECTRONIC CO.,LTD.  
TEL:886-2-26577778;FAX:886-2-26575659

A		E2210-001	X 0	新增12PIN規格	Lonlon	2022/9/27	UNLESS OTHERWISE SPECIFIED TOLERANCE 尺寸公差 X. ±0.50 .X ±0.25 .XX ±0.15 .XXX ±0.10 ANG. ±2'00	CHECKED 審核 DESIGNED 設計 London 2022/9/27	UNIT 單位 MM	TITLE 產品名稱 USB TYPE-C PLUG 12PIN PACKAGING SPECIFICATIONS	SHEET 頁碼 3/3
REV. 版本	ECN NO. 設變號碼	MARK 記號	REVISIONS 設變內容	SIGN 修改	DATE 日期	ANG.	APPROVED 承認	DRAWN 製圖 London 2022/9/27	SCALE 比例 1/1	PART NO. 產品料號 M30-0866-00002	REV. 版本 A
1	2	3	4	5	6	7	8	9	10		