

ITEM 項目	PARTS NAME 零件名稱	Q'TY 數量	MATERIAL 材質	FINISH/REMARK 處理/備註
1	HOUSING	1	SYNTHETIC RESIN	(Black)
2	SHELL	1	STAINLESS	PLATING Ni:20U"
3	CONTACT	5	COPPER ALLOY	Gold:8u";Tin:100u";Ni:30u"
4	CAP	1	SYNTHETIC RESIN	(Black)

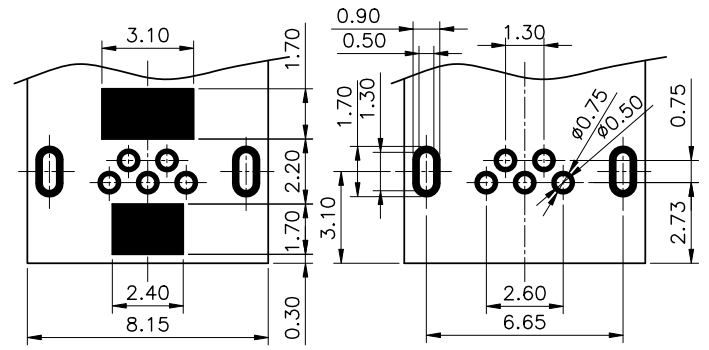
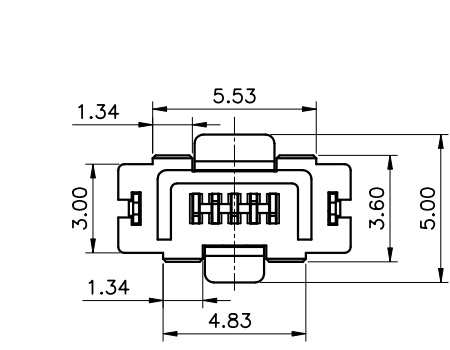

PCB TOP PCB BOTTOM

RECOMMENDED P.C.B. LAYOUT  
TOLERANCE ±0.03mm)

NOTES  
 1.MATERIAL: See drawing  
 2.ELECTRICAL  
 2.1.Insulator resistance: 100M ohms Min. @ 500 VDC  
 2.2.Withstanding voltage: 100 VAC / minute  
 2.3.Contact resistance: 60m ohms Max.  
 3.MECHANICAL  
 3.1.Mating force: 35N(3.43kgf) Max.  
 3.2.Unmating force: 8N~20N(0.81~2.04kgf) Min.  
 3.3.Durability: 10000 cycles Min.  
 3.4.Contact retention force: 2.1N(0.21kgf) Min  
 4.PACKING: 500pcs/bag (reference)  
 5.PART NO.  
 M30 - 0717 - 0 0 045  
 SERIES Connector MODEL NO. 0717  
 TYPE NO. 045=Type 45  
 PROCESS NO. "0"  
 MATERIAL TYPE 0=Semi-finished goods



**WALTA** 華大電子股份有限公司  
 WALTA ELECTRONIC CO.,LTD.  
 TEL.886-2-26577778;FAX.886-2-26575659

REV. 版本	ECN NO. 設變號碼	MARK 記號	REVISIONS 設變內容	SIGN 修改	DATE 日期
B	E2009-001	△ X 1	修改鐵殼鉤合扣形狀	CR	2020/8/27
A	E1810-002	△ X 0	原M30-0717-00038增加CAP規格	Lonlon	2018/10/10

UNLESS OTHERWISE SPECIFIED TOLERANCE 尺寸公差	CHECKED 審核	DESIGNED 設計
.X ±0.50	Lonlon	2018/10/10
.X ±0.30	APPROVED 承認	DRAWN 製圖
.XX ±0.20		Lonlon
ANG. ±5'00"		2018/10/10

TITLE 產品名稱	UNIT 單位	SCALE 比例	PART NO. 產品料號	REV. 版本
ASS'Y HOUSING	MM	1/1	M30-0717-00045	B
		SIZE 尺寸	DOC. NO. 文件編號	
		A4	CUT-0717-102	