

RECOMMEND PC BOARD LAYOUT
TOLERANCE: 0.05mm

NOTES:
1.MATERIAL:
HOUSING: LCP, UL94V-0, Black
CONTACT: PHOSPHOR BRONZE (C5210R-EH)
SHELL: STAINLESS STEEL (SUS304R-3/4H)
2.FINISH:
CONTACT AREA: SELECTED GOLD PLATED
SOLDER AREA: G/F GOLD PLATED
UNDER PLATING: NICKEL PLATED
SHELL:
SOLDER AREA: G/F GOLD PLATED
UNDER PLATING: NICKEL PLATED.
3.SPECIFICATION:
CURRENT RATING: 1A / (1PIN)
VOLTAGE RATING: 30V AC
DIELECTRIC WITHSTANDING: 500V AC FOR 1 MINUTE
CONTACT RESISTANCE: 100mΩ Max.
INSULATION RESISTANCE: 1000MΩ Min
OPERATING TEMPERATURE: -25°C to +70°C
DURABILITY: 5000 CYCLES MIN.
CONTACT RETENTION: 2.5N MIN.
INSERTION FORCE: 9.8N MAX.
WITHDRAWAL FORCE: 2N

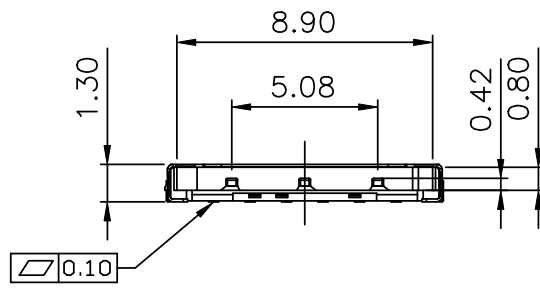

SIM Card Pin Assignments

PIN	Name
C1	Vcc
C2	RST
C3	CLK
C4	Reserved
C5	GND
C6	Vpp
C7	I/O
C8	Reserved

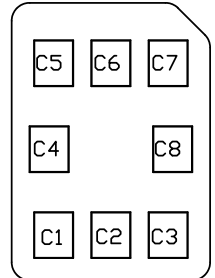

WALTA 華大電子股份有限公司
WALTA ELECTRONIC CO.,LTD.
TEL:886-2-26577778;FAX.886-2-26575659

REV. 版本	ECN NO. 設變號碼	MARK 記號	REVISIONS 設變內容	SIGN 修改	DATE 日期	UNLESS OTHERWISE SPECIFIED TOLERANCE 尺寸公差	CHECKED 審核	DESIGNED 設計	UNIT 單位	TITLE 產品名稱
A	EXXXX-XXX	△ X 0		zhijun	2020/6/5	X. ±0.50 .X ±0.30 .XX ±0.10 ANG. ±5°00'		zhijun 2020/6/5	MM	Nano SIM Push-Pull Type 6Pin H:1.3mm (1/2)
							APPROVED 承認	DRAWN 製圖 zhijun 2020/6/5	SCALE 比例 1/1	PART NO. 產品料號 F03-0121-00001
									SIZE 尺寸 A4	DOC. NO. 文件編號 CUT-0121-001

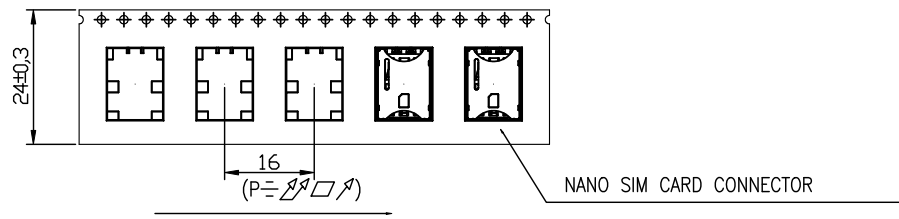

Uφ○○○○○=φ,φ Δ○○○○○ P=□φ

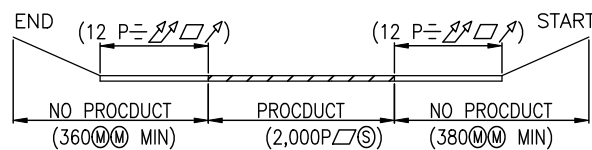
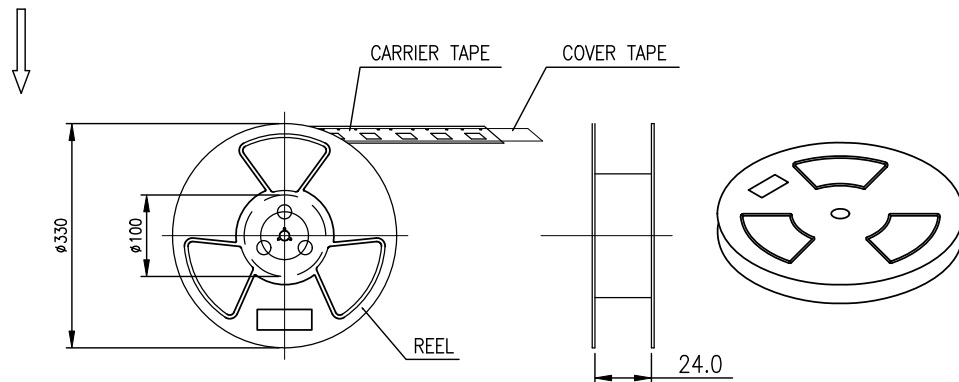

Uφ○○○○○=φ,φ Δ○○○○○ P=□φ

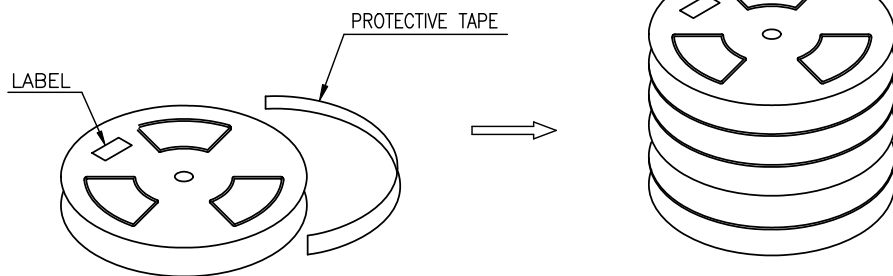

NOTES:

1. PACKING STYLE: 2,000 PCS/REEL
10,000 PCS/OUTER CARTON
2. MATERIAL: CARRIER TAPE: PS BLACK
COVER TAPE: PET FILM
REEL: PLASTIC
3. PEEL STRENGTH OF COVER TAPE: 20~80g(PEEL SPEED 300mm/MINUTE)
4. CARTON SIZE: 350x350x170mm
5. G/W: 5.5 Kg , N/W: 1.5 Kg

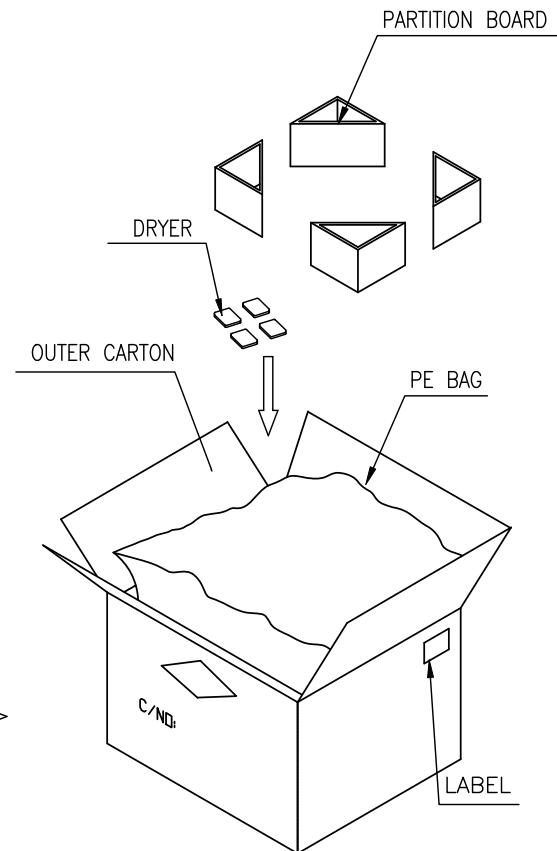

WALTA 華大電子股份有限公司
WALTA ELECTRONIC CO.,LTD.
TEL:886-2-26577778;FAX:886-2-26575659

UNLESS OTHERWISE SPECIFIED TOLERANCE 尺寸公差		CHECKED 審核		DESIGNED 設計		TITLE 產品名稱	
X. ±0.50				zhijun 2020/6/5		Nano SIM Push-Pull Type 6Pin H:1.3mm (2/2)	
.X ±0.30		APPROVED 承認		DRAWN 製圖		SCALE 比例	
.XX ±0.20				zhijun 2020/6/5		1/1	
ANG. ±5°00'						SIZE 尺寸	
						PART NO. 產品料號	
						F03-0121-00001	
						DOC. NO. 文件編號	
						CUT-0121-001	
						REV. 版本	
						A	