

NOTES:  
PEELING OFF FORCE OF THE TOP TAPE:20-100gf  
(PEELING DIRECTION AS SHOWN IN THE FOLLOWING FIGURE)

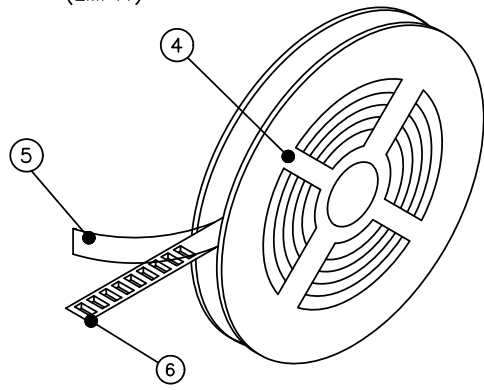

ITEM 項目	PARTS NAME 零件名稱	FINISH/REMARK 處理/備註
1	I/O CONNECTOR	10000 PCS/BOX(REFERENCE)
2	BOX	10 REEL/BOX
3	WATERPROOF BAG	1 PCS
4	REEL	--
5	TOP COVER TAPE	(COLOR:TRANSPARENT)
6	CARRIER TAPE	1000 PCS/REEL(REFERENCE)
7	LABEL	批號標籤

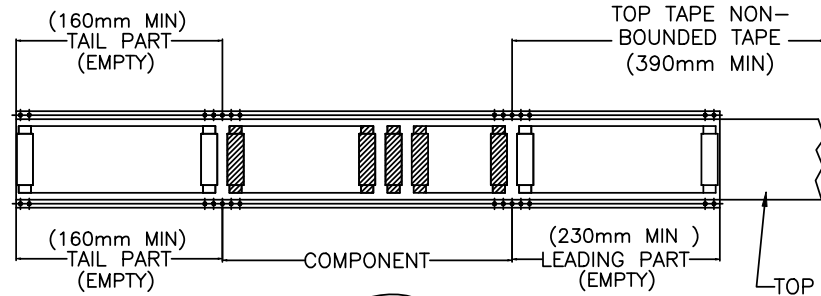
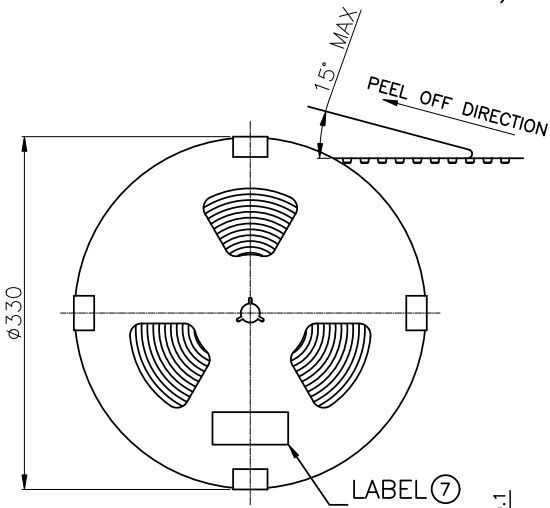
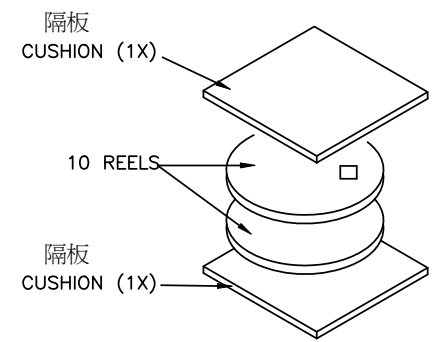

收料方向  
CATERH MATERIAL DIRECTION

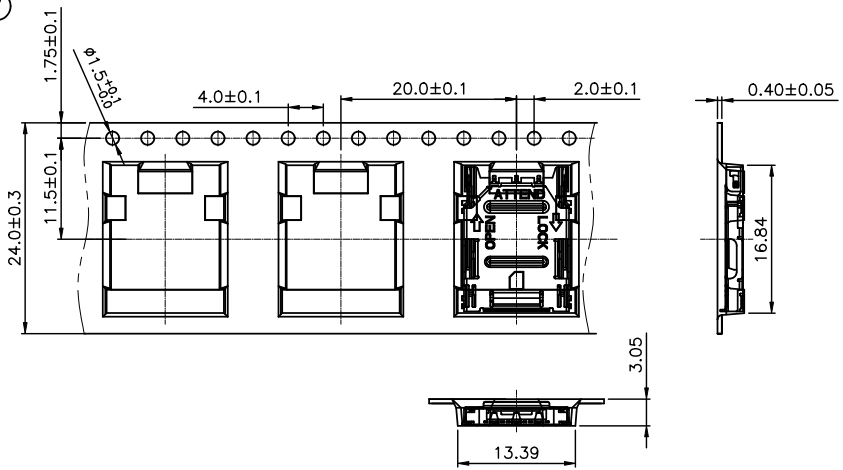

客戶放料方向  
PULL OUT DIRECTION

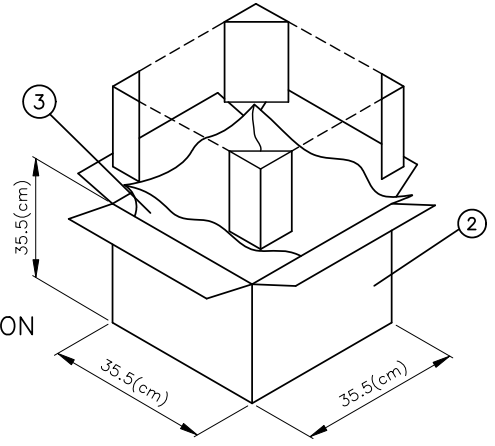

NOTES  
1.MATERIAL: PS (Color: 透明)  
2.DEFORMATION(變形)&DAMAGE(損壞): NA.(不可)  
3.All dimensions meet EIA-481-C requirements.

TAPE REEL成品擺放方向



A		EXXXX-XXX	△ X 0	新開	Lonlon	2019/5/9	UNLESS OTHERWISE SPECIFIED TOLERANCE 尺寸公差 X. ±0.50 .X ±0.30 .XX ±0.20 ANG. ±5'00"	CHECKED 審核	DESIGNED 設計 Lonlon 2019/5/9	UNIT 單位 MM	TITLE 產品名稱 nano SIM CONNECTOR (2/2)	
REV. 版本	ECN NO. 設變號碼	MARK 記號	REVISIONS 設變內容	SIGN 修改	DATE 日期			APPROVED 承認	DRAWN 製圖 Lonlon 2019/5/9	SCALE 比例 1/1	PART NO. 產品料號 E03-0855-06001	REV. 版本 A