

ITEM 項目	PARTS NAME 零件名稱	Q'TY 數量	MATERIAL 材質	FINISH/REMARK 處理/備註
1	Insemold Housing	1	PA-9T	(Black)UL94 V-0
2	CONTACT	24	C18400	Au:30u" on contact area, Matte Tin:100u" Min on solder tails, Base Nickel:50u"
3	MID-PLATE	1	SUS301	NON Plating
4	INNER SHELL	1	SUS304	Ni:50u" Min
5	OUTER SHELL	1	SUS304	Ni:50u" Min

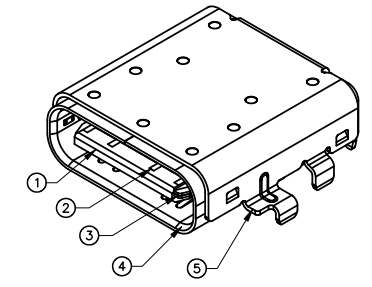

**SPECIFICATION**

**MATERIAL**  
See drawing  
**STANDARD DATA**

**Rating current:**  
5.0A for VBUS (i.e.,pins A4,A9,B4,B9)  
1.25A for Vconn and GND (i.e.,pins B5,A1,A12,B1,B12)  
0.25A for all the other contacts.  
**Operating temperature:** -10°C ~ +60°C  
**Storage temperature:** -20°C ~ +85°C  
**ELECTRICAL**  
**Insulator resistance:** 100Mohms Min.  
**Withstanding voltage:** 100 VAC / minute  
**Contact resistance:** initial 40mohms Max;  
after 50mohms Max.

**MECHANICAL**

**Mating force:** 5~20N  
**Unmating force :** Initial 8~20N  
After 10000 cycles 6~20N  
**Durability:** 10000 cycles Min.  
**PART NO.**

SERIES D 1 3 - 0871 - 24 001  
D=I/O Connector  
TYPE 1=0.5mm pitch  
CONTACT TYPE 3=SMT type  
MODEL NO. TYPE NO. 001=Type 001  
CONTACT NUMBER 24=24position



**WALTA** 華大電子股份有限公司  
WALTA ELECTRONIC CO.,LTD.  
TEL:886-2-26577778;FAX:886-2-26575659

REV. 版本	ECN NO. 設變號碼	MARK 記號	REVISIONS 設變內容	SIGN 修改	DATE 日期	UNLESS OTHERWISE SPECIFIED TOLERANCE 尺寸公差	CHECKED 審核	DESIGNED 設計	UNIT 單位	TITLE 產品名稱	PART NO. 產品料號	SHEET 頁碼
A	N2023-001	X 0	新開	London	2023/3/28	X. ±0.50 .X ±0.25 .XX ±0.15 .XXX ±0.10 ANG. ±2'00'	APPROVED 承認	London	MM	USB TYPE C RECEPTACLE Mid mount, Dual-Row SMT, CH=1.10mm	D13-0871-24001	1/3
REV. 版本	ECN NO. 設變號碼	MARK 記號	REVISIONS 設變內容	SIGN 修改	DATE 日期	UNLESS OTHERWISE SPECIFIED TOLERANCE 尺寸公差	CHECKED 審核	DESIGNED 設計	SCALE 比例	DOC. NO. 文件編號	CUT-0871-001	REV. 版本 A

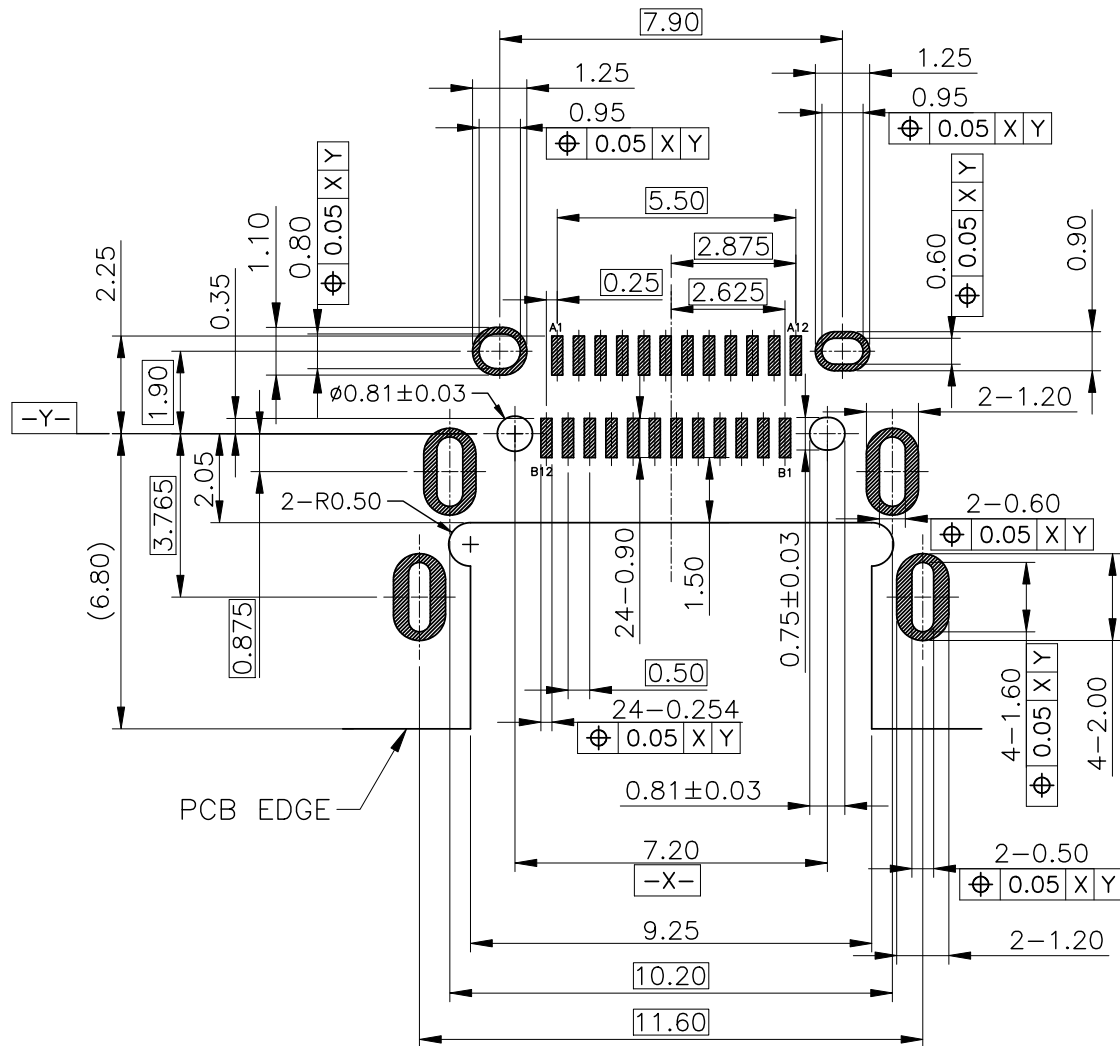

RECOMMENDED PCB LAYOUT(TOP VIEW)  
TOLERANCE:±0.05

Pin Number	Signal Name	Pin Number	Signal Name
A1	GND	B12	GND
A2	SSTxp1	B11	SSRxp1
A3	SSTxn1	B10	SSRxn1
A4	VBUS	B9	VBUS
A5	CC1	B8	SBU2
A6	DP1	B7	DN2
A7	DN1	B6	DP2
A8	SBU1	B5	CC2
A9	VBUS	B4	VBUS
A10	SSRxn2	B3	SSTxn2
A11	SSRxp2	B2	SSTxp2
A12	GND	B1	GND



**WALTA** 華大電子股份有限公司  
WALTA ELECTRONIC CO.,LTD.  
TEL:886-2-26577778;FAX:886-2-26575659

REV. 版本	ECN NO. 設變號碼	MARK 記號	REVISIONS 設變內容	SIGN 修改	DATE 日期	UNLESS OTHERWISE SPECIFIED TOLERANCE 尺寸公差 X. ±0.50 .X ±0.25 .XX ±0.15 .XXX ±0.10 ANG. ±2°00'	CHECKED 審核	DESIGNED 設計 London 2023/3/28	UNIT 單位 MM	TITLE 產品名稱 USB TYPE C RECEPTACLE Mid mount, Dual-Row SMT, CH=1.10mm	
A	N2023-001	△ X 0	新開	London	2023/3/28		APPROVED 承認	DRAWN 製圖 London 2023/3/28	SCALE 比例 1/1	PART NO. 產品料號 D13-0871-24001	SHEET 頁碼 2/3
									SIZE 尺寸 A4	DOC. NO. 文件編號 CUT-0871-001	REV. 版本 A

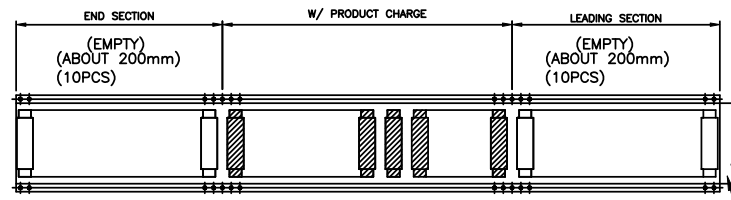
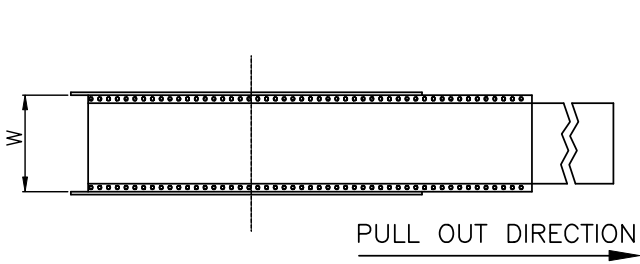

ITEM 項目	PARTS NAME 零件名稱	FINISH/REMARK 處理/備註
1	I/O CONNECTOR	9000 PCS/BOX(REFERENCE)
2	BOX	12 REEL/BOX
3	WATERPROOF BAG	1 PCS
4	REEL	--
5	COVER TAPE	(COLOR:TRANSPARENT)
6	CARRIER TAPE	750 PCS/REEL(REFERENCE)
7	LABEL	批號標籤

TOP COVER TAPE

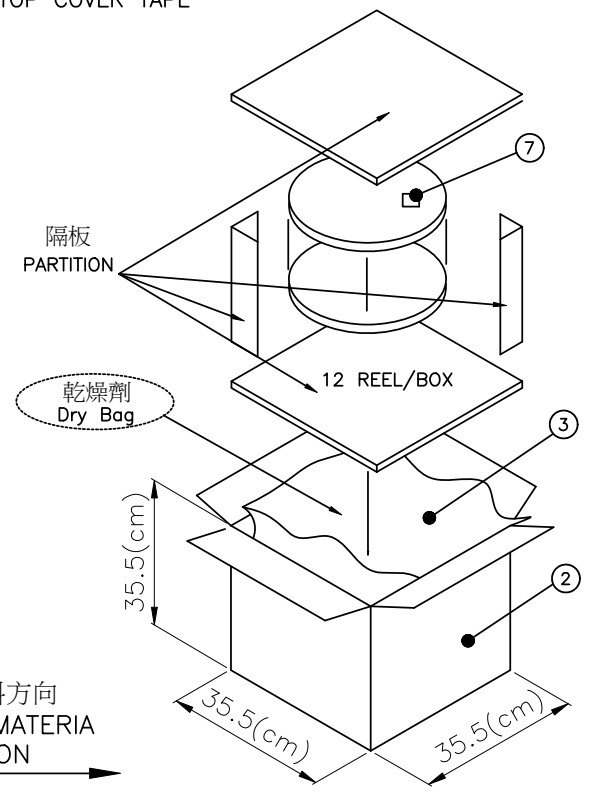
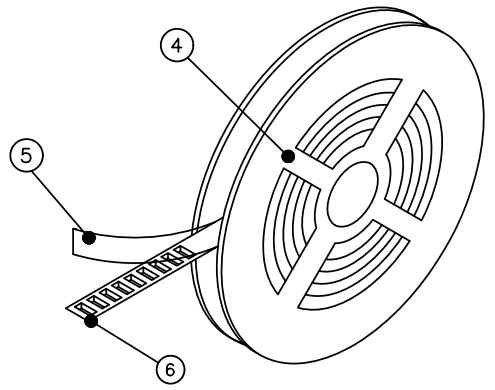
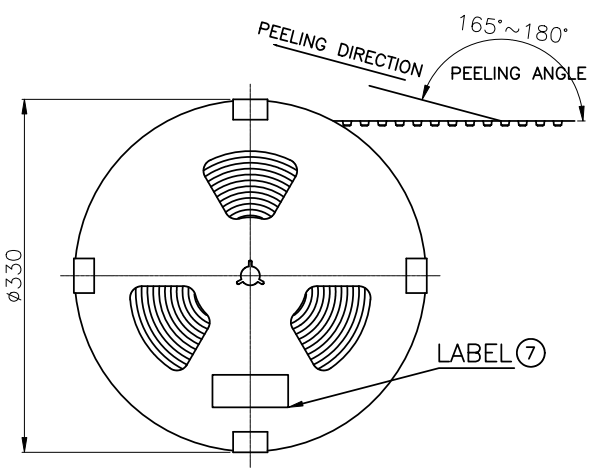

客戶放料方向  
INPUT MATERIA  
DIRECTION

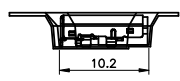
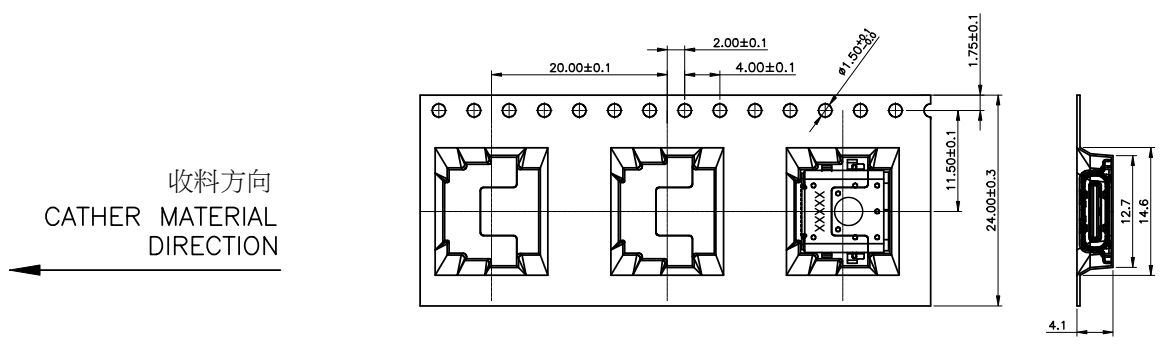

TAPE REEL成品擺放方向

- NOTES
- 1.MATERIAL: PET (Color: 透明)
  - 2.DEFORMATION(變形)&DAMAGE(損壞): NA.(不可)
  - 3.All dimensions meet EIA-481 requirements.

RoHS  
Compliant

**WALTA** 華大電子股份有限公司  
WALTA ELECTRONIC CO.,LTD.  
TEL:886-2-26577778;FAX:886-2-26575659

A		N2023-001	X 0	新開	Lonlon	2023/3/28	UNLESS OTHERWISE SPECIFIED TOLERANCE 尺寸公差 X. ±0.50 .X ±0.30 .XX ±0.20 ANG. ±5'00"	CHECKED 審核 DESIGNED 設計 Lonlon 2023/3/28	UNIT 單位 MM	TITLE 產品名稱 USB TYPE C RECEPTACLE Mid mount, Dual-Row SMT, CH=1.10mm	SHEET 頁碼 3/3		
REV. 版本	ECN NO. 設變號碼	MARK 記號	REVISIONS 設變內容			SIGN 修改	DATE 日期	APPROVED 承認	DRAWN 製圖 Lonlon 2023/3/28	SCALE 比例 1/1	PART NO. 產品料號 D13-0871-24001	DOC. NO. 文件編號 CUT-0871-001	REV. 版本 A