

ITEM 項目	PARTS NAME 零件名稱	Q'TY 數量	MATERIAL 材質	FINISH/REMARK 處理/備註
1	HOUSING	1	LCP E130i	Black(UL-94-V0)
2	CONTACT	19	C2680	BASE NICKEL:50u"; Au:5~7u" ON CONTACT AREA; 100u" Matte TIN ON SOLDER TAILS.
3	SHELL	1	SUS304	NICKEL:50u" Min.

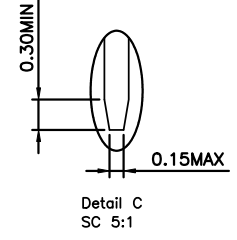

SPECIFICATION
MATERIAL
 See drawing
STANDARD DATA
 Voltage Rating:40V AC
 Rating current:0.5A(per pin)
ELECTRICAL
 Insulator resistance: 100 Mohms Min. @ 500 VDC
 Withstanding voltage: 500 VAC/minute
 Contact resistance: Initial 30 mohms Max.
 After test:60 mohms Max.
MECHANICAL
 Insertion force: 44.1N(4.5Kgf) Max.
 Withdrawal force: 9.8~39.2N(1.0~4.0Kgf).
 Durability: 10000 cycles Min.
PART NO.

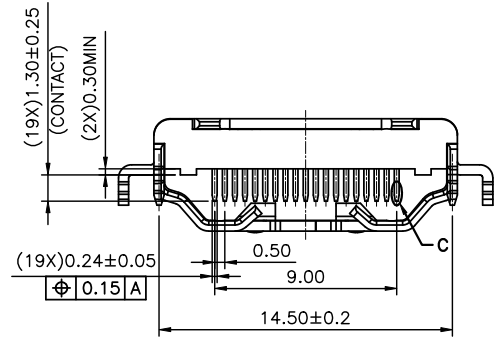
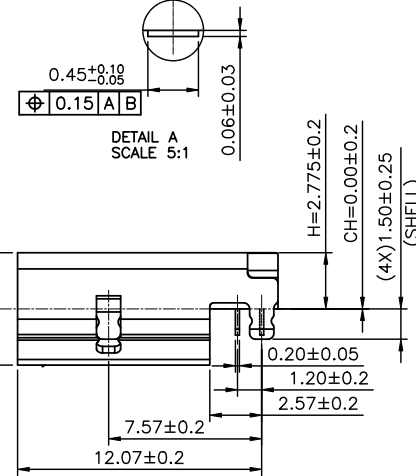
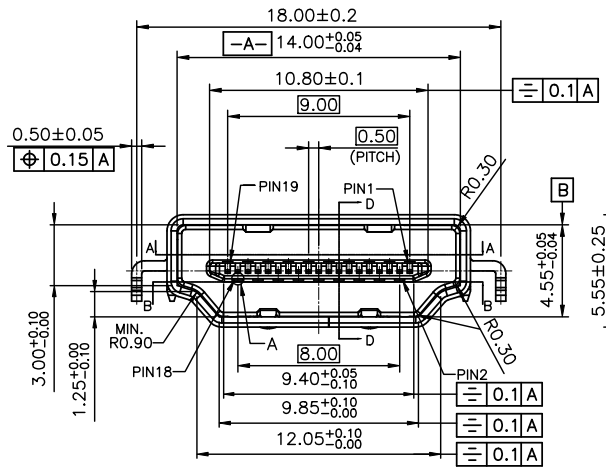
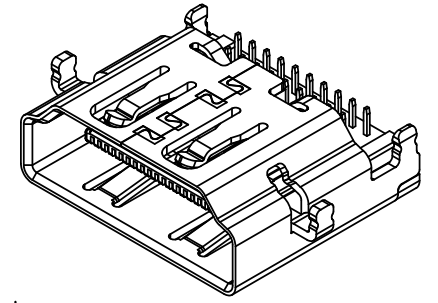
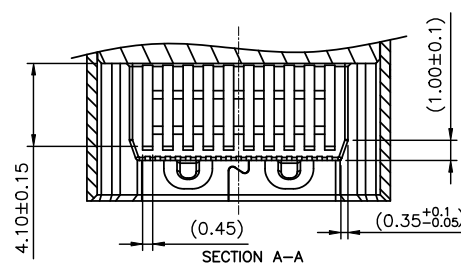
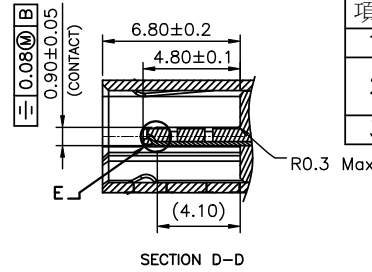
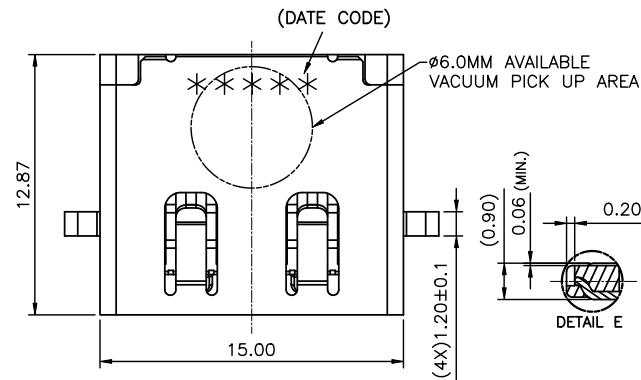
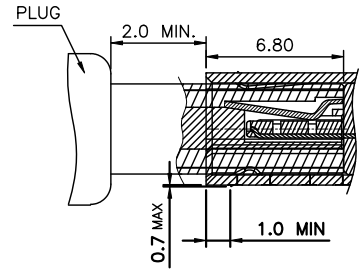
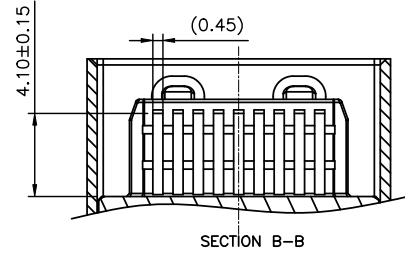

SERIES D13 - 0865 - 19 01 X
 MODEL NO. CONTACT TYPE
 D13=I/O CONNECTOR X=DIP type
 0.5mm pitch TYPE NO.
 01=Type 01
 CONTACT NUMBER
 19=19position



WALTA 華大電子股份有限公司
 WALTA ELECTRONIC CO.,LTD.
 TEL:886-2-26577778;FAX:886-2-26575659

REV. 版本	ECN NO. 設變號碼	MARK 記號	REVISIONS 設變內容	SIGN 修改	DATE 日期	UNLESS OTHERWISE SPECIFIED TOLERANCE 尺寸公差 .X ±0.25 .XX ±0.15 .XXX ±0.10 ANG. ±2°00'	CHECKED 審核	DESIGNED 設計 Lonlon 2020/9/15	UNIT 單位 MM	TITLE 產品名稱
A	EXXXX-XXX	X 0	新開	Lonlon	2020/9/15		APPROVED 承認	DRAWN 製圖 Lonlon 2020/9/15	SCALE 比例 1/1 SIZE 尺寸 A4	PART NO. 產品料號 D13-0865-1901X DOC. NO. 文件編號 CUT-0865-001

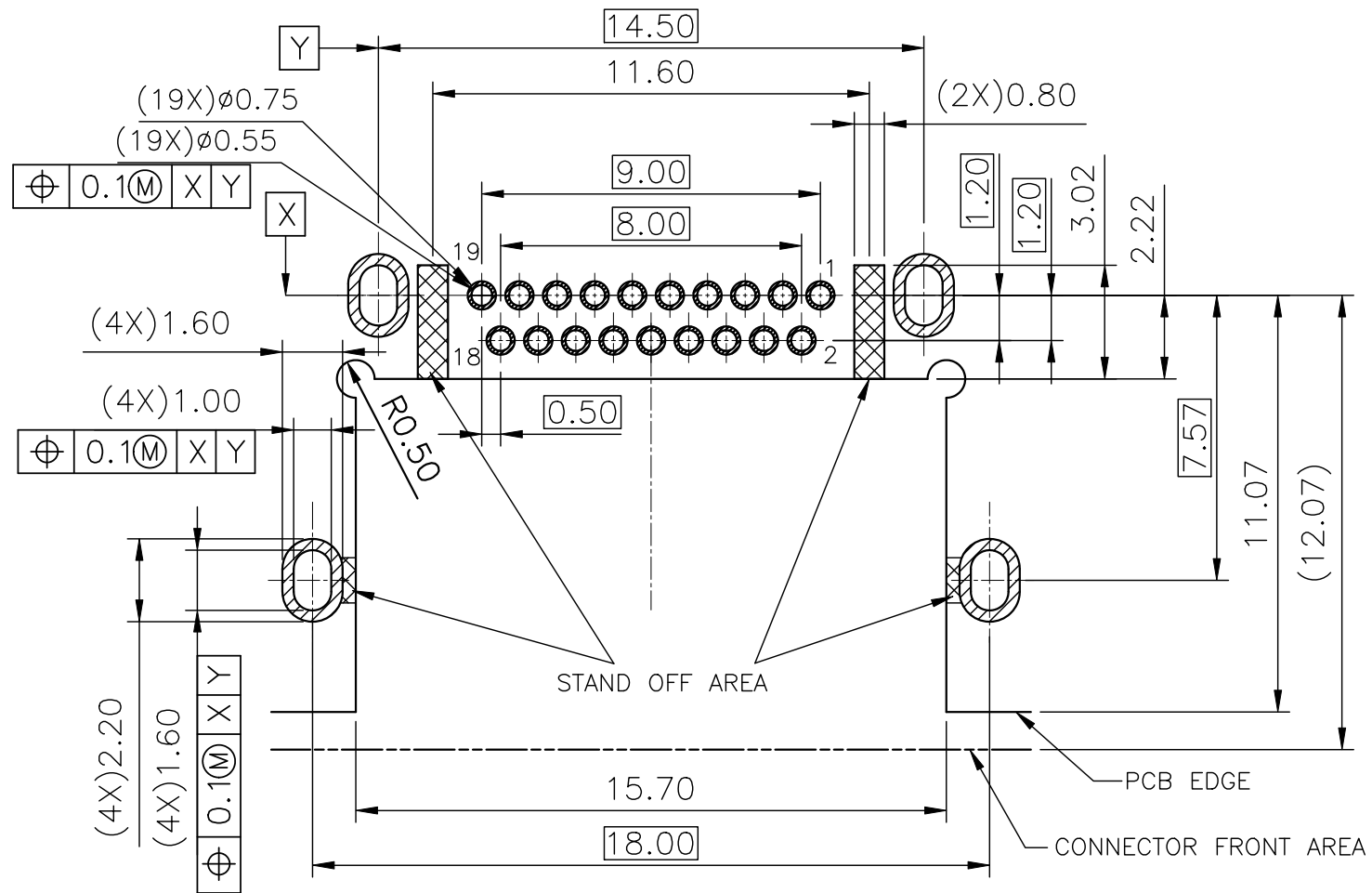

PIN	Signal Assignment
1	TMDS Data2+
2	TMDS Data2 Shield
3	TMDS Data2-
4	TMDS Data1+
5	TMDS Data1 Shield
6	TMDS Data1-
7	TMDS Data0+
8	TMDS Data0 Shield
9	TMDS Data0-
10	TMDS Clock+
11	TMDS Clock Shield
12	TMDS Clock-
13	CEC
14	Utility
15	SCL
16	SDA
17	DDC/CEC Ground
18	+5V Power
19	Hot Plug Detect

RECOMMENDED P.C.B LAYOUT (THICKNESS: 1.20mm)
COMPONENT SIDE (TOL: ±0.05)



WALTA 華大電子股份有限公司
 WALTA ELECTRONIC CO., LTD.
 TEL: 886-2-26577778; FAX: 886-2-26575659

REV. 版本	ECN NO. 設變號碼	MARK 記號	REVISIONS 設變內容	SIGN 修改	DATE 日期	UNLESS OTHERWISE SPECIFIED TOLERANCE 尺寸公差 .X ±0.25 .XX ±0.15 .XXX ±0.10 ANG. ±2°00'	CHECKED 審核	DESIGNED 設計 London 2020/9/15	SCALE 比例 1/1	TITLE 產品名稱 HDMI 19P STANDARD RECEPTACLE DIP TYPE, CH=0.00mm	REV. 版本 2/3
A	EXXXX-XXX	△ X 0	新開	London	2020/9/15		APPROVED 承認	DRAWN 製圖 London 2020/9/15	SIZE 尺寸 A4	PART NO. 產品料號 D13-0865-1901X	A
										DOC. NO. 文件編號 CUT-0865-001	

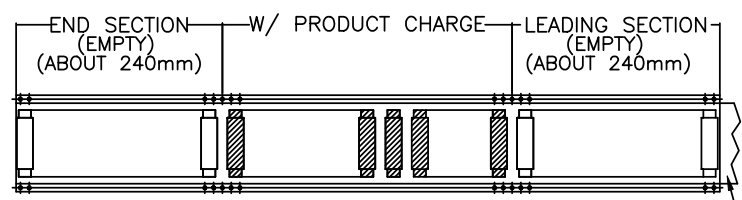
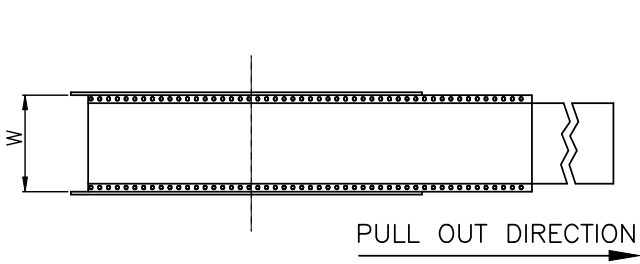

ITEM 項目	PARTS NAME 零件名稱	FINISH/REMARK 處理/備註
1	I/O CONNECTOR	3200 PCS/BOX(REFERENCE)
2	BOX	8 REEL/BOX
3	WATERPROOF BAG	1 PCS
4	REEL	--
5	COVER TAPE	(COLOR:TRANSPARENT)
6	CARRIER TAPE	400 PCS/REEL(REFERENCE)
7	LABEL	批號標籤

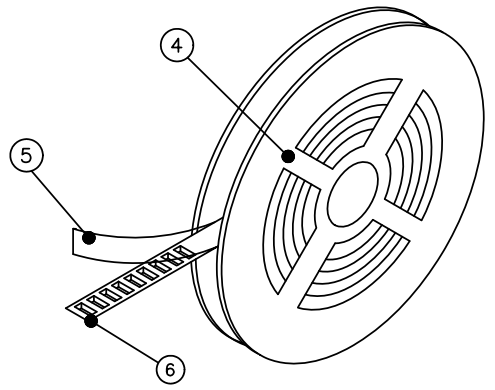
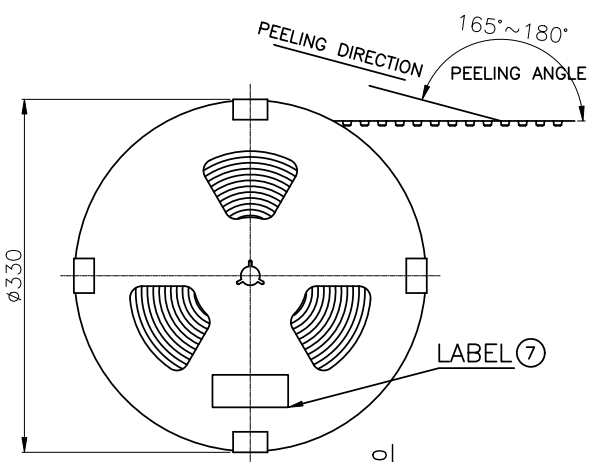

TOP COVER TAPE

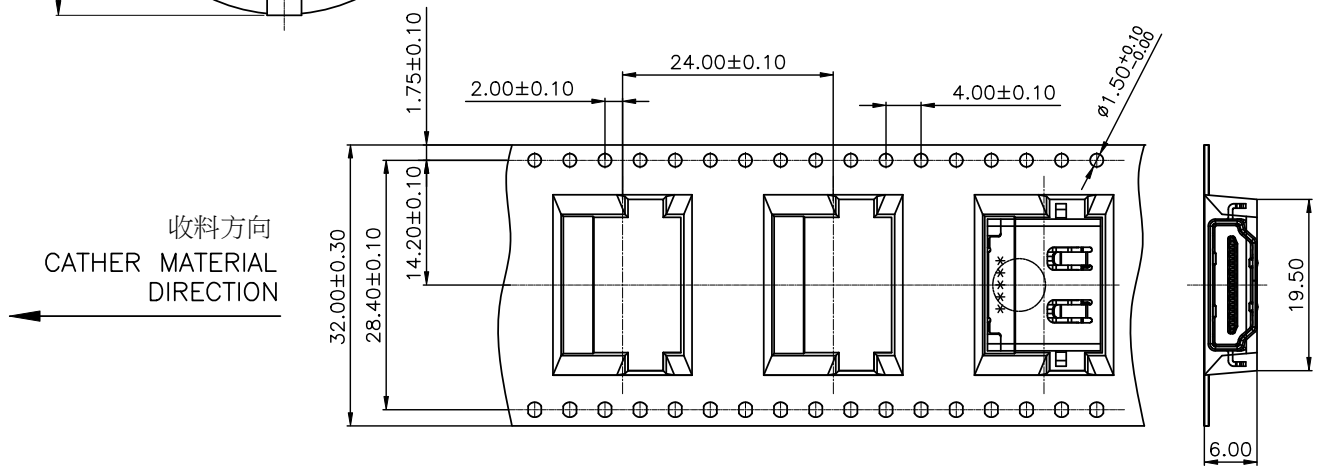
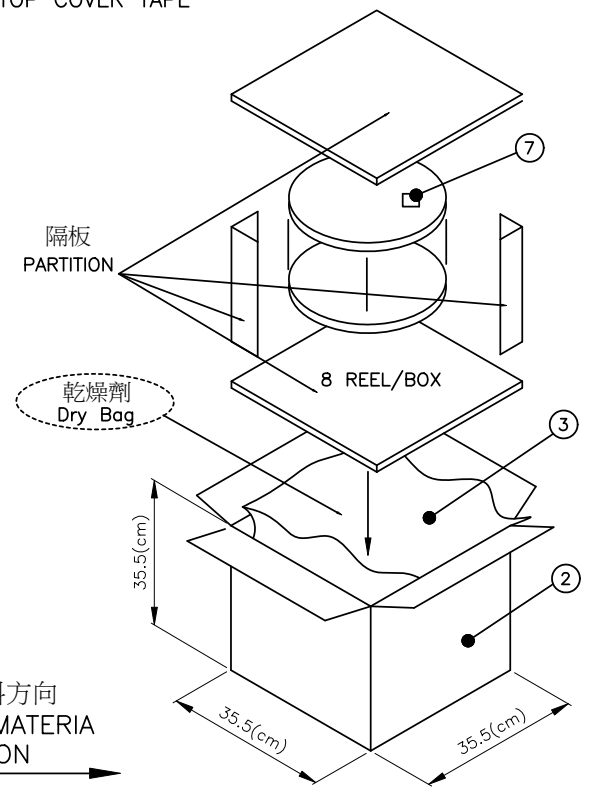

客戶放料方向 INPUT MATERIA DIRECTION

TAPE REEL成品擺放方向

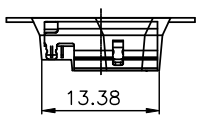

- NOTES
- 1.MATERIAL: PS (Color: 透明)
 - 2.DEFORMATION(變形)&DAMAGE(損壞): NA.(不可)
 - 3.All dimensions meet EIA-481-C requirements.

Process Capable

RoHS Compliant

WALTA

華大電子股份有限公司
WALTA ELECTRONIC CO.,LTD.
TEL:886-2-26577778;FAX:886-2-26575659

REV. 版本	ECN NO. 設變號碼	MARK 記號	REVISIONS 設變內容	SIGN 修改	DATE 日期	UNLESS OTHERWISE SPECIFIED TOLERANCE 尺寸公差	CHECKED 審核	DESIGNED 設計	UNIT 單位	TITLE 產品名稱
A	EXXXX-XXX	△ X 0	新開	Lonlon	2020/9/15	X. ±0.50 .X ±0.30 .XX ±0.20 ANG. ±5'00"	APPROVED 承認	Lonlon 2020/9/15	MM	3/3
								Lonlon 2020/9/15	SCALE 比例 1/1 SIZE A4	PART NO. 產品料號 D13-0865-1901X DOC. NO. 文件編號 CUT-0865-001