

ITEM 項目	PARTS NAME 零件名稱	Q'TY 數量	MATERIAL 材質	FINISH/REMARK 處理/備註
1	Insermold housing	1	SYNTHETIC RESIN	Black(UL94V-0)
2	CONTACT	1	COPPER ALLOY	GOLD 5U" ON CONTACT AREA, 100u" Min TIN ON SOLDER AREA,Ni:50u"
3	SHELL	1	STAINLESS	Ni:60u"
4	Shield	1	STAINLESS	-

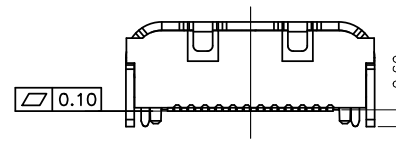
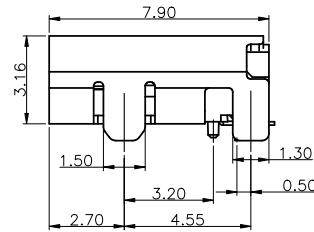
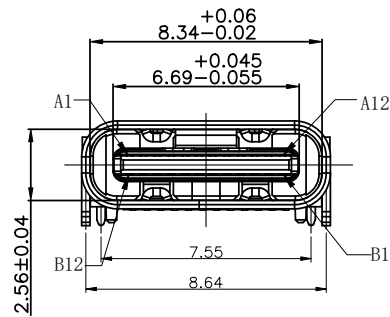
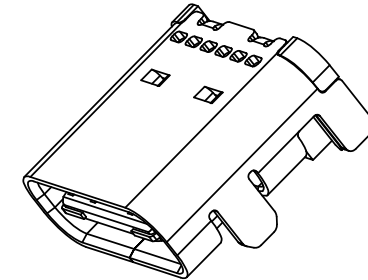
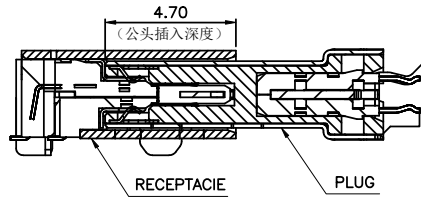
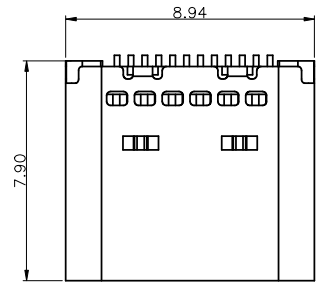

- SPECIFICATION**
- MATERIAL: See drawing
 - STANDARD DATA
 - Rating current: 3.0A for VBUS; 0.25A for all the other contacts.
 - ELECTRICAL
 - Insulator resistance: 100M ohms Min.
 - Withstanding voltage: 100 VAC / minute
 - Contact resistance: initial 40mohms Max. after 50mohms Max.
 - MECHANICAL
 - Mating force: 5~20N
 - Unmating force: Initial 8~20N After 10000cycles 6~20N
 - Durability: 10000 cycles Min.

A1	GND	B12	GND
A2	SSTXP1	B11	SSRXP1
A3	SSTXN1	B10	SSRXN1
A4	VBUS	B9	VBUS
A5	CC1	B8	SBU2
A6	DP1	B7	DN2
A7	DN1	B6	DP2
A8	SBU1	B5	CC2
A9	VBUS	B4	VBUS
A10	SSRXN2	B3	SSTXN2
A11	SSRXP2	B2	SSTXP2
A12	GND	B1	GND
PIN	SIGNAL NAME	PIN	SIGNAL NAME

PART NO. D 1 3 - 0824 - 24 018

SERIES D
D=I/O Connector

TYPE 1
1=0.5mm pitch

CONTACT TYPE 3
3=SMT type

MODEL NO. 0824 - 24

TYPE NO. 018
018=Type 18
CONTACT NUMBER
24=24position

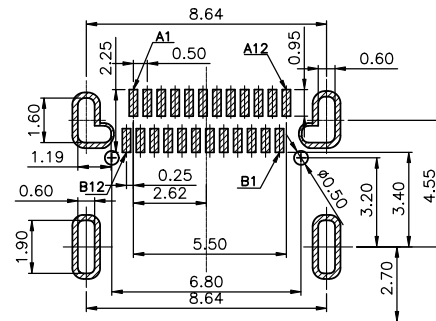
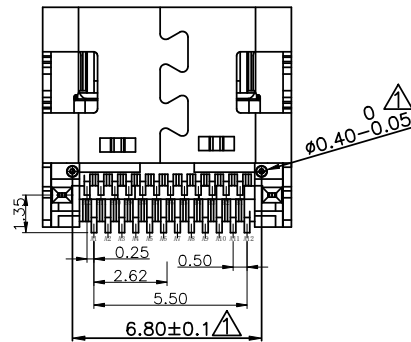

RECOMMENDED P.C.B. LAYOUT
TOLERANCE UNSPECIFIED ±0.05mm



WALTA 華大電子股份有限公司
WALTA ELECTRONIC CO.,LTD.
TEL:886-2-26577778;FAX:886-2-26575659

REV. 版本	ECN NO. 設變號碼	MARK 記號	REVISIONS 設變內容	SIGN 修改	DATE 日期	UNLESS OTHERWISE SPECIFIED TOLERANCE 尺寸公差	CHECKED 審核	DESIGNED 設計	UNIT 單位	TITLE 產品名稱	PART NO. 產品料號	REV. 版本
B	E1812-003	△ X 1	修改定位柱公差。	zhijun	2018/12/12	.X ±0.50	huabo	huabo	MM	USB C TYPE CONNECTOR	D13-0824-24018	B
A	E1608-002	△ X 0	原D13-0824-24013新增端子5U"規格	TANG	2016/8/8	.X ±0.30 .XX ±0.20 ANG. ±5°0'	huabo	huabo	1/1		D13-0824-24018	B
1							APPROVED 承認	DRAWN 製圖	SCALE 比例	DOC. NO. 文件編號	CUT-0824-016	

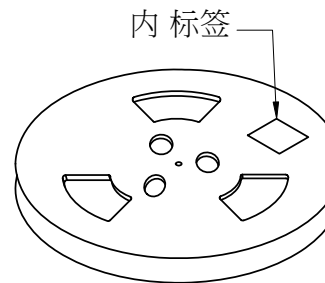

① 卷盘贴标签示意图

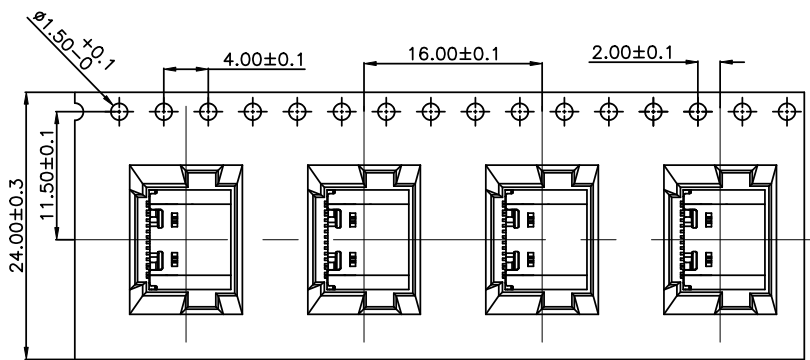

② 产品入载带示意图

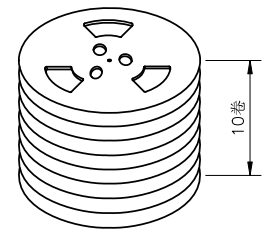

③ 10盘产品叠层示意图

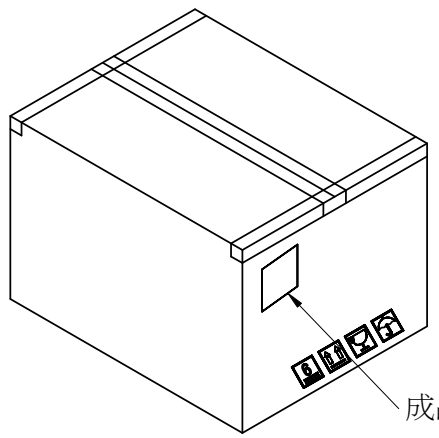

⑥ 外箱封箱示意图

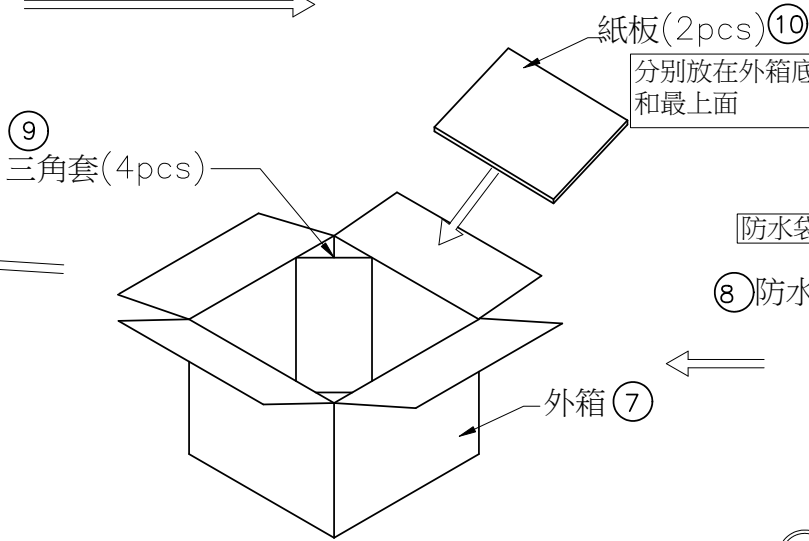

⑤ 产品入外箱示意图

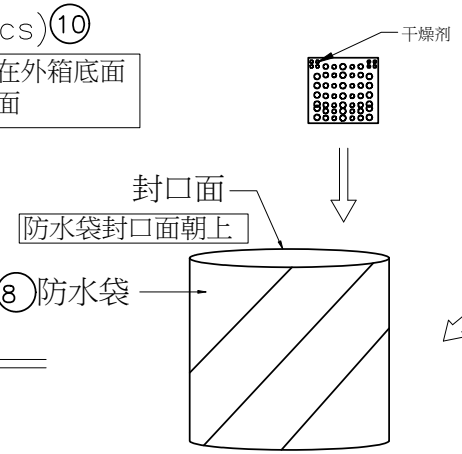

④ 10盘产品入防水袋示意图

图四

图三

包装说明:

1. 将检验好的成品;SMT朝下放入载带底部;每卷装900PCS产品,9000PCS/箱;具体如图一所示
2. 将包装好的产品;每盘必需贴上内标签;具体如图二所示
3. 将贴好内标签的产品每10盘叠一层装入防水袋中并加一包干燥剂;装好后将防水袋封好;具体如图三图四所示
4. 先将1pcs平卡放入纸箱底部;然后将装好产品的防水袋装入纸箱中;防水袋热熔封口,封口面需朝上;并将4PCS三角套分别装入4个角;如图五所示
5. 装好后将1pcs平卡放入纸箱最上面并封好纸箱及贴好相关标签;具体如图六所示;
(产品包装的标签,如客户有要求,请按客户要求包装出货)



WALTA 華大電子股份有限公司
WALTA ELECTRONIC CO.,LTD.
TEL:886-2-26577778;FAX:886-2-26575659

UNLESS OTHERWISE SPECIFIED TOLERANCE 尺寸公差		CHECKED 審核	DESIGNED 設計	TITLE 產品名稱	
.X ±0.50		huabo	2016/8/8	USB C TYPE CONNECTOR	
.X ±0.30		APPROVED 承認	DRAWN 製圖	SCALE 比例	PART NO. 產品料號
.XX ±0.20		huabo	huabo	1/1	D13-0824-24018
ANG. ±5°00'			2016/8/8	SIZE 尺寸	DOC. NO. 文件編號
				A4	CUT-0824-016
REV. 版本	ECN NO. 設變號碼	MARK 記號	REVISIONS 設變內容	SIGN 修改	DATE 日期
B	E1812-003	△ X 1	修改定位柱公差。	zhijun	2018/12/12
A	E1608-002	△ X 0	原D13-0824-24013新增端子5U”規格	Tang	2016/8/8