

RECOMMENDED P.C.B. LAYOUT
TOLERANCE UNSPECIFIED ±0.05mm

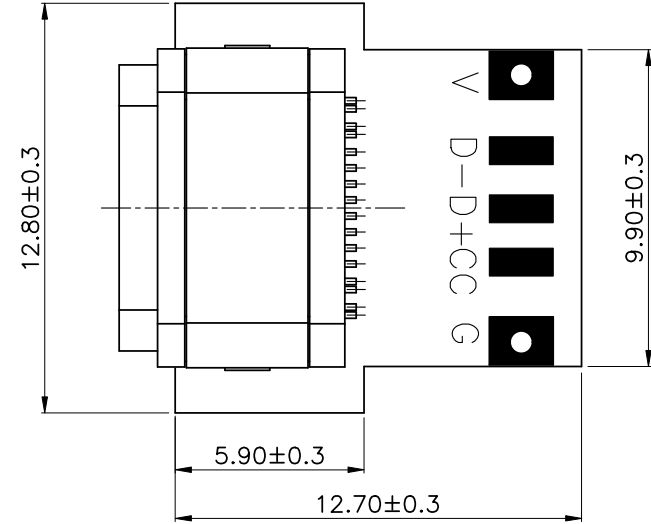

ITEM 項目	PARTS NAME 零件名稱	Q'TY 數量	MATERIAL 材質	FINISH/REMARK 處理/備註
1	HOUSING-1	1	LCP	(Black) UL94V-0
2	CONTACT	16	C2680	Gold flash on contact area 80~120u" Tin on solder tails, base Ni:50u"
3	SHELL-1	1	SUS304	Ni:30u"Min
4	SHELL-2	1	SUS304	Ni:30u"Min
5	HOUSING-2	1	LCP	(Black) UL94V-0
6	SHIELDIGN PLATE	1	SUS301	Non-Plating
7	RUBBER RING	1	RUBBER	Black
8	PCB	1	-	-

A1	GND	B12	GND
A4	VBUS	B9	VBUS
A5	CC1	B8	SBU2
A6	DP1	B7	DN2
A7	DN1	B6	DP2
A8	SBU1	B5	CC2
A9	VBUS	B4	VBUS
A12	GND	B1	GND
PIN	SIGNAL NAME	PIN	SIGNAL NAME

SPECIFICATION:

- CURRENT RATING: 3.0A MAX
- VOLTAGE: 100 VAC
- TEMPERATURE RANGE: -30 °C ~ 85 °C
- CONTACT RESISTANCE: 40 MILLIONHM MAX
- INSULATION RESISTANCE: 100 MEGOHMS MIN.
- INSERTION FORCE : 5N~20N
- UNMATING FORCE: 8N~20N
- DURABILITY: 10,000 CYCLES
- WATER PROOFNESS: THIS PRODUCT IS BASED ON IPX7.
- PART NO

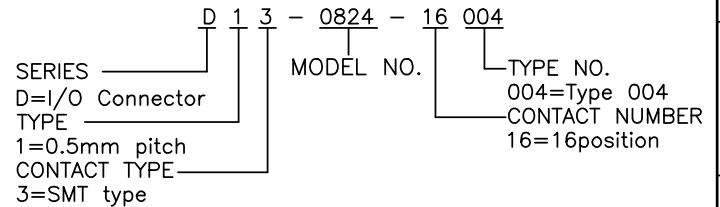

WALTA 華大電子股份有限公司
WALTA ELECTRONIC CO.,LTD.
TEL:886-2-26577778;FAX:886-2-26575659

REV. 版本	ECN NO. 設變號碼	MARK 記號	REVISIONS 設變內容	SIGN 修改	DATE 日期	UNLESS OTHERWISE SPECIFIED TOLERANCE 尺寸公差	CHECKED 審核	DESIGNED 設計	UNIT 單位	TITLE 產品名稱	PART NO. 產品料號	REV. 版本
A	E2009-008	X 0	新增帶PCB規格	CR	2020/9/25	X. ±0.50 .X ±0.30 .XX ±0.20 ANG. ±5°00'		CR 2020/9/25	MM	TYPE C母座16PIN防水型 帶PCB板	D13-0824-16004	1/3
							APPROVED 承認	DRAWN 製圖 CR 2020/9/25	SCALE 比例 1/1 SIZE 尺寸 A4	DOC. NO. 文件編號 CUT-0824-039		A

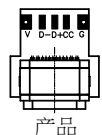

产品

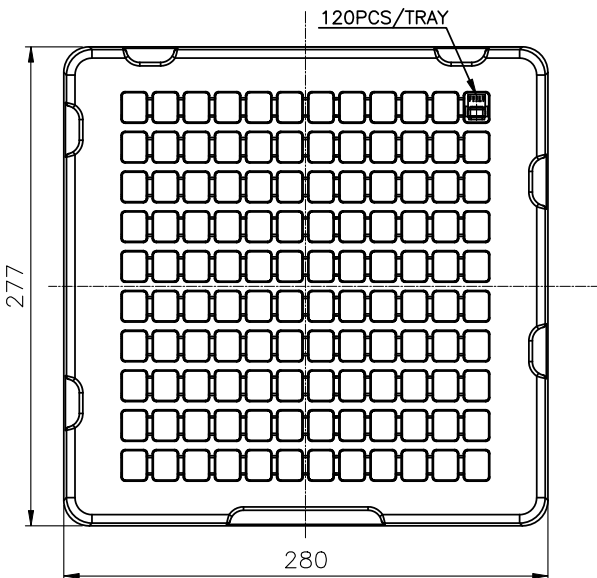

吸塑盘
120PCS/盘

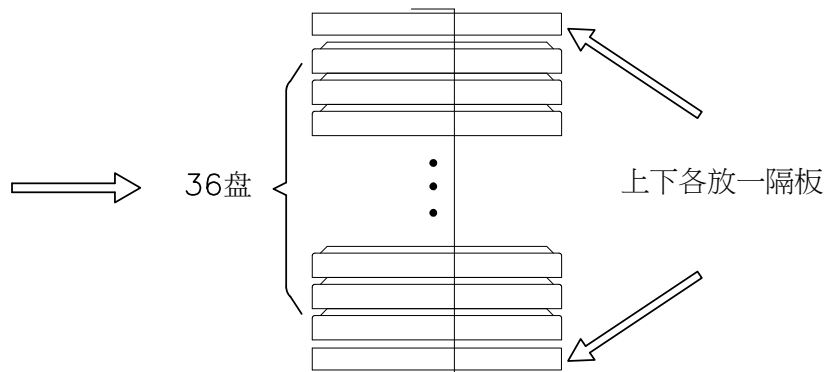

36盘/箱，最上面放空盘共4320PCS

将产品放入到PE袋中放干燥剂并封口，
然后放入到纸箱中。

备注:

- 1.将全检后的良品如图示摆入规格为280*277的PET透明吸塑盘中,每盘包装120PCS
- 2.将装好成品的吸塑盘(36盘,最上面为空盘)用PE膜捆好,上下各放一个隔板,然后套一个PE袋,放入干燥剂封住PE袋,最后放入纸箱中,每箱放36盘,每箱装4320PCS.
- 3.装好后用封胶纸将纸箱封好,并在纸箱右上角贴上对应产品的标签.

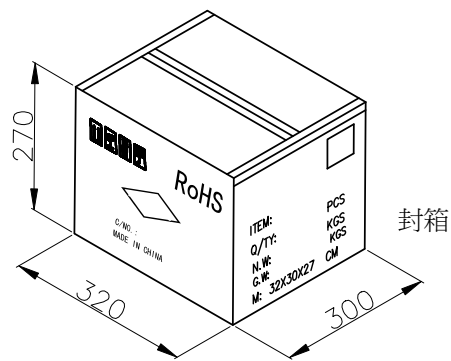

封箱

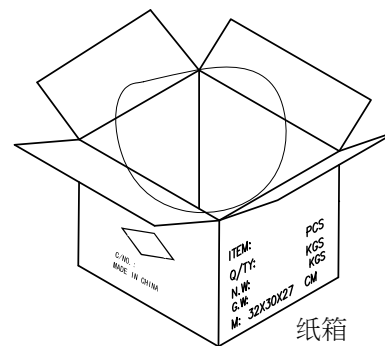

纸箱



華大電子股份有限公司
WALTA ELECTRONIC CO.,LTD.
TEL:886-2-26577778;FAX:886-2-26575659

UNLESS OTHERWISE SPECIFIED TOLERANCE 尺寸公差		CHECKED 審核	DESIGNED 設計	TITLE 產品名稱	
X. ±0.50			lonlon	TYPE C母座16PIN防水型	
.X ±0.30		APPROVED 承認	2020/9/25	UNIT 單位	2/3
.XX ±0.20			lonlon	SCALE 比例	PART NO. 產品料號
ANG. ±5'00"			2020/9/25	1/1	D13-0824-16004
				SIZE 尺寸	DOC. NO. 文件編號
				A4	CUT-0824-039
REV. 版本	ECN NO. 設變號碼	MARK 記號	REVISIONS 設變內容	SIGN 修改	DATE 日期
A	E2009-008	△ X 0	新增帶PCB規格	CR	2020/9/25

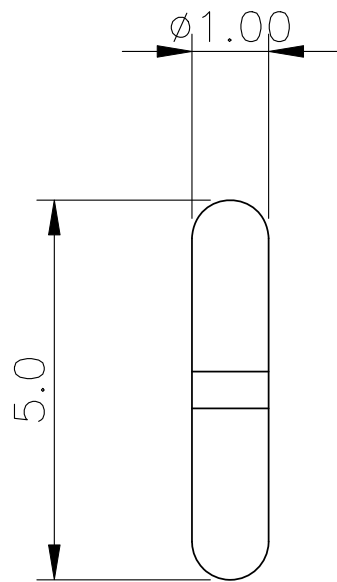
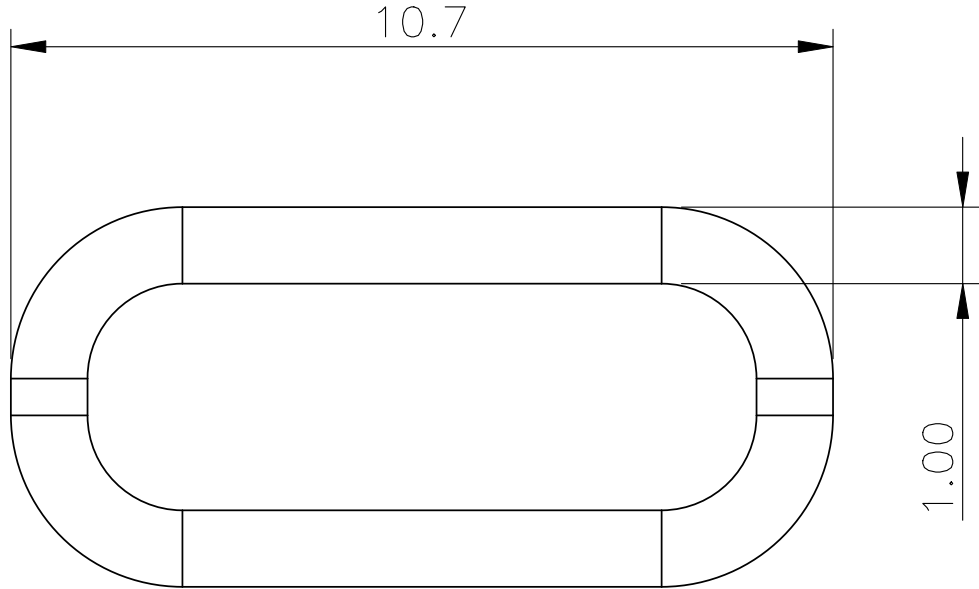

备注：使用工作溫度-15°C~200°C
 材質為NBR 黑色，硬度60±5°C。
 不能有缺膠，損傷，縮水，翹曲，發斑等不良。
 分型面段差0.05mm Max,毛邊0.15mm Max.

PART NO. M28 - 0824 - 9 0 002
 SERIES M28 TYPE NO. 002=Type 2
 PLASTIC MATERIAL MODEL NO. 0824 PROCESS NO. "0"
 MATERIAL TYPE 9=SEAL RING



華大電子股份有限公司
 WALTA ELECTRONIC CO.,LTD.
 TEL:886-2-26577778;FAX:886-2-26575659

UNLESS OTHERWISE SPECIFIED TOLERANCE 尺寸公差		CHECKED 審核	DESIGNED 設計	TITLE 產品名稱
X. ±0.20			CR	TYPE C母座圓形防水圈
.X ±0.10		APPROVED 承認	2020/9/25	UNIT 單位 MM
.XX ±0.05			DRAWN 製圖	SCALE 比例 1/1
ANG. ±1°00'			CR	PART NO. 產品料號 M28-0824-90002
			2020/9/25	DOC. NO. 文件編號 CUT-0824-039
REV. 版本	ECN NO. 設變號碼	MARK 記號	REVISIONS 設變內容	SIGN 修改
A	E2009-008	△ x 0	-	CR 2020/9/25