

ITEM 項目	PARTS NAME 零件名稱	Q'TY 數量	MATERIAL 材質	FINISH/REMARK 處理/備註
1	HOUSING	1	LCP	Black
2	SPRING	1	SUS301	Black
3	CONTACT	20	C2680	Gold Flash on contact area, Tin:100u" on solder area under 50u" Nickle
4	SHELL	1	SUS201	Ni:30u"Min

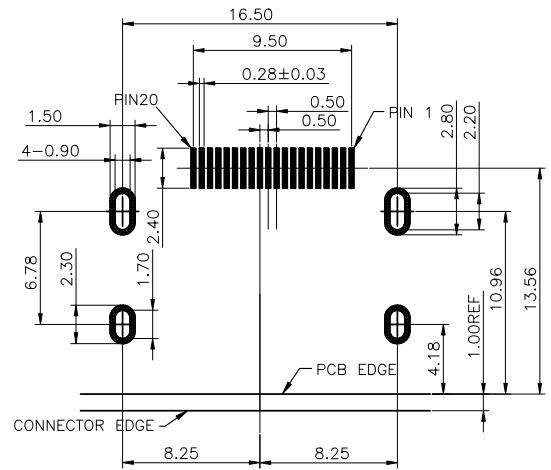

RECOMMENDED P.C.B. LAYOUT(PCB THICKNESS: 1.6mm)  
COMPONENT SIDE VIEW(TOLERANCE: ±0.05)

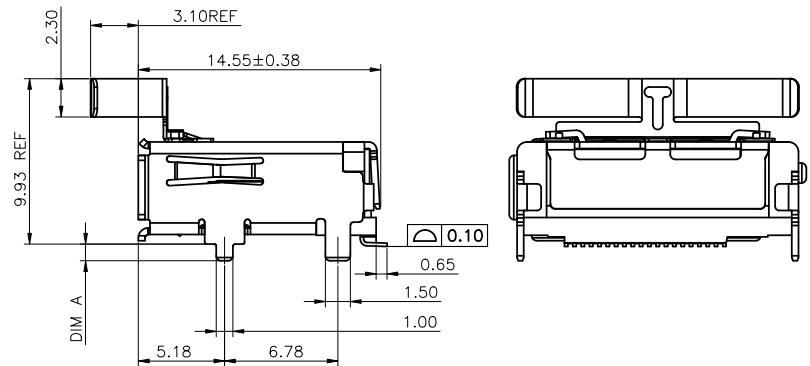
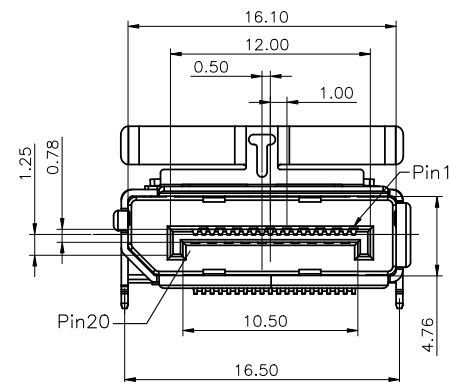

DIM 尺寸  
1: DIM A=1.0  
2: DIM A=1.4  
3: DIM A=2.0

- NOTES:  
1. ELECTRICAL PERFORMANCE  
1.1 Rated Voltage: 40V  
1.2 Rated Current: 0.5A Max.  
1.3 CONTACT RESISTANCE : 40m OHMS MAX.  
1.4 INSULATION RESISTANCE: 100MΩ MIN.  
1.5 DIELECTRIC WITHSTANDING VOLTAGE;500V AC(RMS)  
2.MECHANICAL PERFORMANCE  
2.1 INSERTION FORCE : 4.5kgf MAX.  
2.2 EXTRACTION FORCE : 1.0~4.0kgf MIN.  
2.3 DURABILITY:10000 CYCLES  
3. OPERATING TEMPERATURE:-20°C~+85°C  
4.PART NO.

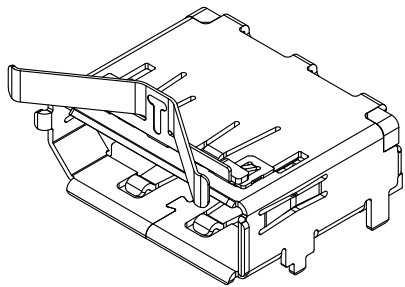
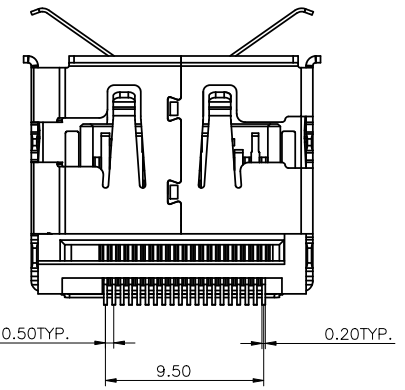

SERIES D 06 - C 124 - 020 0X  
D=I/O Connector  
CONN TYPE NO. 06=type 6  
FORM OF FACTORY C=Connector of factory  
TYPE NO. 0X=Type X  
CONTACT NUMBER 020=20 position  
FACTORY CODE



華大電子股份有限公司  
WALTA ELECTRONIC CO.,LTD.  
TEL:886-2-26577778;FAX:886-2-26575659

REV. 版本	ECN NO. 設變號碼	MARK 記號	REVISIONS 設變內容	SIGN 修改	DATE 日期	UNLESS OTHERWISE SPECIFIED TOLERANCE 尺寸公差 X. ±0.50 .X ±0.30 .XX ±0.20 ANG. ±5°00'	CHECKED 審核	DESIGNED 設計 zhijun 2022/8/15	UNIT 單位 MM	TITLE 產品名稱 DP 90°SMT 20PIN 帶彈片 无底盖 1/2	
A	EXXXX-XXX	△ X 0		zhijun	2022/8/15		APPROVED 承認	DRAWN 製圖 zhijun 2022/8/15	SCALE 比例 1/1	PART NO. 產品料號 D06-C124-0200X	REV. 版本 A
1									SIZE 尺寸 A4	DOC. NO. 文件編號 CUT-C124-009	

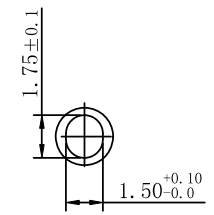
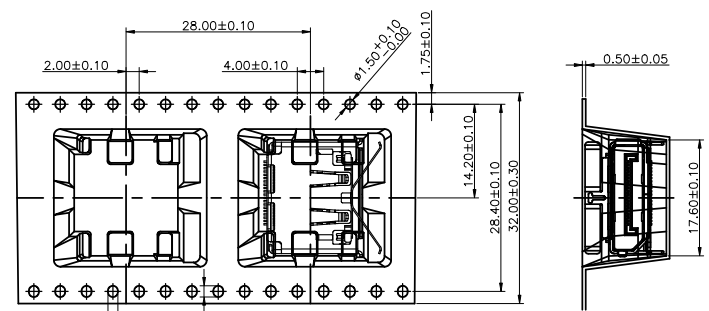
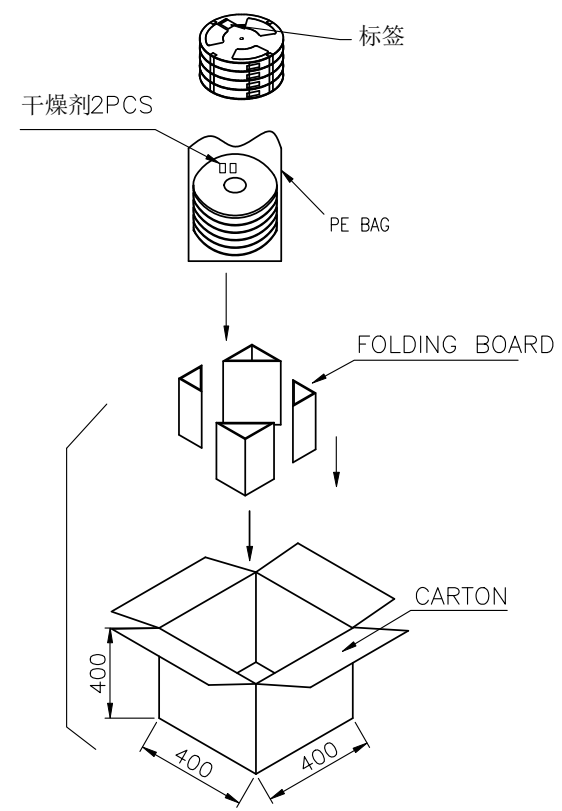
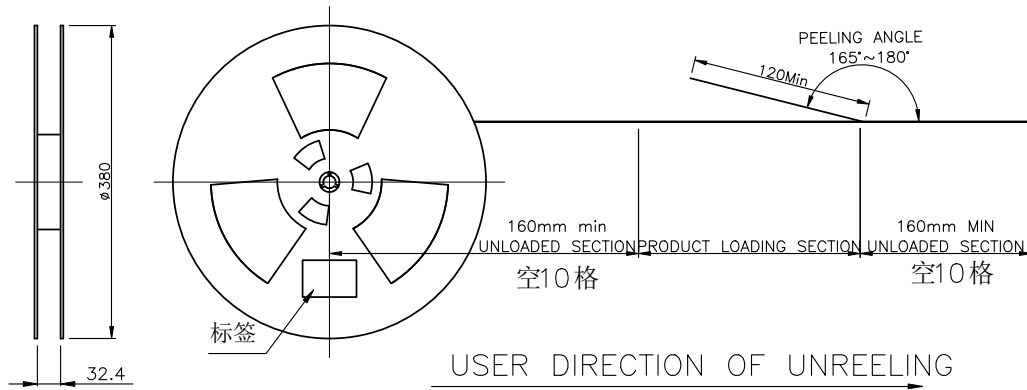

DETAIL A  
10:1

240	10	2400 PCS	--KG	--KG
PCS/REEL	REELS/CARTON	QUANTITY	GROSS WEIGHT	NET WEIGHT



**WALTA** 華大電子股份有限公司  
WALTA ELECTRONIC CO.,LTD.  
TEL:886-2-26577778;FAX:886-2-26575659

REV. 版本	ECN NO. 設變號碼	MARK 記號	REVISIONS 設變內容	SIGN 修改	DATE 日期	UNLESS OTHERWISE SPECIFIED TOLERANCE 尺寸公差 X. ±0.50 .X ±0.30 .XX ±0.20 ANG. ±5°00'	CHECKED 審核	DESIGNED 設計 zhijun 2022/8/15	UNIT 單位 MM	TITLE 產品名稱 DP 90°SMT 20PIN 帶彈片 无底盖
A	EXXXX-XXX	△ X 0		zhijun	2022/8/15		APPROVED 承認	DRAWN 製圖 zhijun 2022/8/15	SCALE 比例 1/1	PART NO. 產品料號 D06-C124-0200X
								SIZE 尺寸 A4	DOC. NO. 文件編號 CUT-C124-009	REV. 版本 2/2 A