

ITEM	PARTS NAME	Q'TY	MATERIAL	FINISH/REMARK
1	SHELL	1	STAINLESS	20u" NICKEL,100u" TIN
2	CONTACT	5	COPPER ALLOY	Gold flash Plating Over All 15u" Gold flash on Contact AREA
3	HOUSING	1	SYNTHETIC RESIN	(Black)

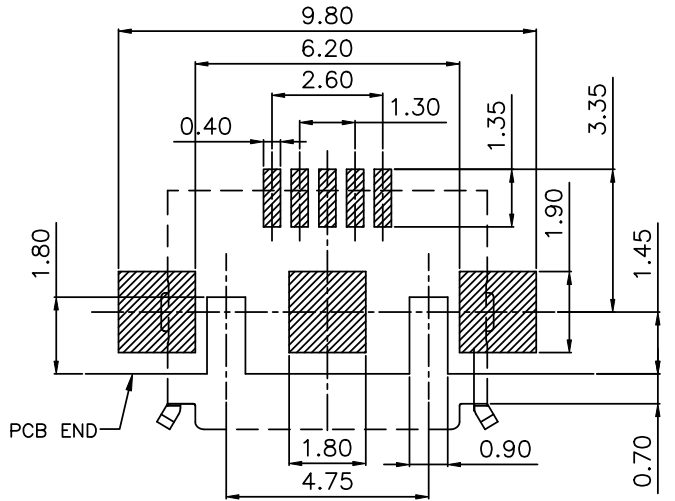

RECOMMENDED P.C. BOARD LAYOUT
(TOLERANCE: ±0.05mm)

SPECIFICATION
MATERIAL
See drawing
STANDARD DATA
Rating current:(1&5PIN)1.8A; (2&3&4PIN)0.5A
ELECTRICAL
Insulator resistance: 1000m ohms Min. @ 500 VDC
Withstanding voltage: 100 VAC / minute
Contact resistance: 30 m ohms
MECHANICAL
Mating force: 35N(3.57kgf) Max.
Unmating force (Without lock): 8N(0.81kgf) Min.
Durability: 10000 cycles Min.
Contact retention force: 2.1N(0.21kgf) Min
PART NO.

SERIES D=I/O Connector
TYPE 0=Other pitch CONTACT TYPE 3=SMT type
MODEL NO. D 0 3 - 0718 - 05 001
TYPE NO. 001=Type 1 05=05position



WALTA 華大電子股份有限公司
WALTA ELECTRONIC CO.,LTD.
TEL:886-2-26577778;FAX:886-2-26575659

F	E2006-008	△ X 0	修改包裝數量	CR	2020/6/29	UNLESS OTHERWISE SPECIFIED TOLERANCE 尺寸公差 .X ±0.50 .XX ±0.30 .XX ±0.20 ANG. ±5°00'	CHECKED 審核	DESIGNED 設計 LUHB	TITLE 產品名稱 I/O CONNECTOR(MICRO USB) <<REVERSE TYPE>> 1/2	
E	E1304-007	△ X 1	修改鐵殼結合形狀	huabo	2013/4/12			11/12/07'		UNIT 單位 MM
D	E1205-016	△ X 1	修改額定電流的規格	XJQ	2012/5/22			SCALE 比例 1/1		PART NO. 產品料號 D03-0718-05001
REV. 版本	ECN NO. 設變號碼	MARK 記號	REVISIONS 設變內容	SIGN 修改	DATE 日期	APPROVED 承認	DRAWN 製圖 LUHB	SCALE 比例 1/1	PART NO. 產品料號 D03-0718-05001	REV. 版本 F
1	2	3	4	5	6	8	9	10		

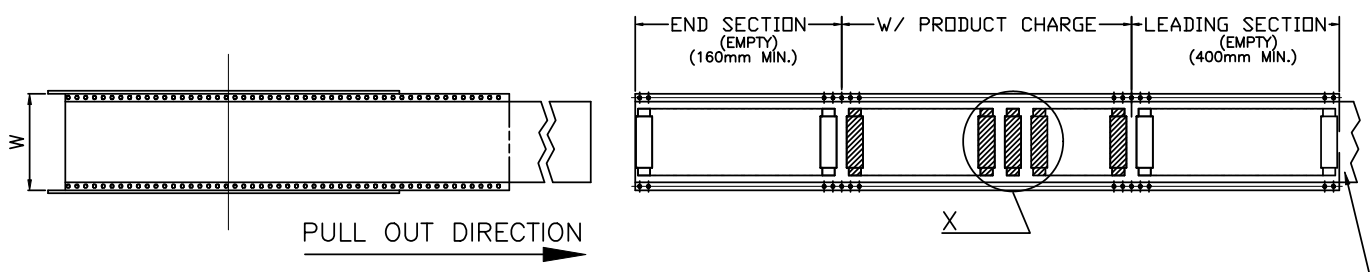

ITEM 項目	PARTS NAME 零件名稱	FINISH/REMARK 處理/備註
△ 1	I/O CONNECTOR	24000 PCS/BOX
2	BOX	12PCS REEL/BOX
3	WATERPROOF BAG	1 PCS
4	REEL	--
5	COVER TAPE	Wide=11.3mm
△ 6	CARRIER TAPE	2000PCS/REEL
7	LABEL	批號標籤

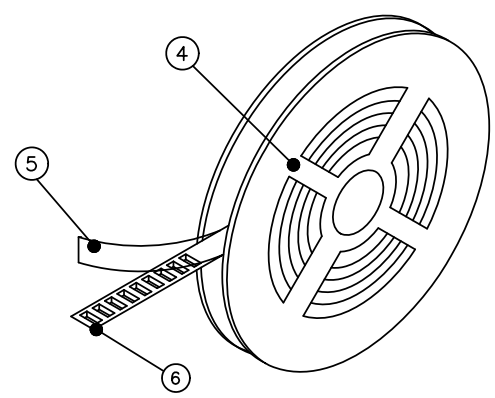
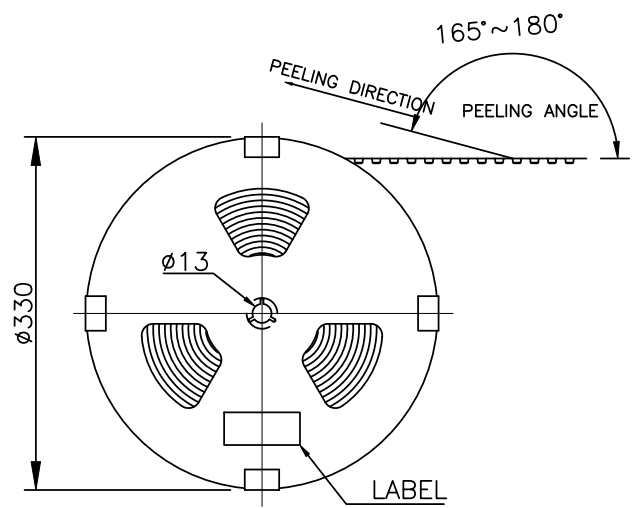

TOP COVER TAPE

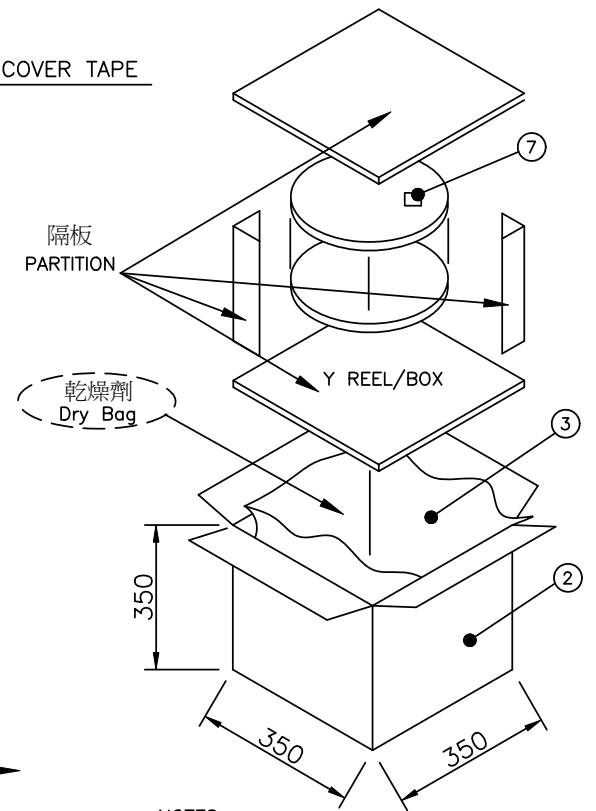

NOTES
 1.MATERIAL: PS (Color: 黑色)
 2.DEFORMATION(變形)&DAMAGE(損壞): NA.(不可)
 3.All dimensions meet EIA-481-C requirements.

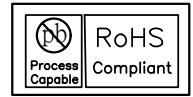
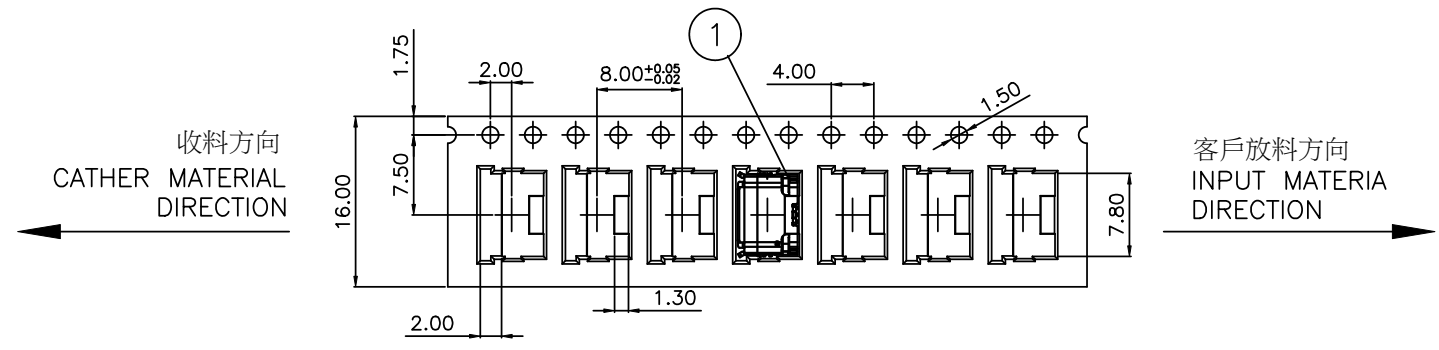

WALTA 華大電子股份有限公司
 WALTA ELECTRONIC CO.,LTD.
 TEL:886-2-26577778;FAX:886-2-26575659

F	E2006-008	△ X 2	修改包裝數量	CR	2020/6/29	UNLESS OTHERWISE SPECIFIED TOLERANCE 尺寸公差 .X ±0.50 .XX ±0.30 .XX ±0.20 ANG. ±5°0'	CHECKED 審核	DESIGNED 設計 LUHB 2008/04/23	TITLE 產品名稱 I/O CONNECTOR (SMT TYPE) 2/2
E	E1304-007	△ X 1	修改鐵殼結合形狀	huabo	2013/4/12		APPROVED 承認	DRAWN 製圖 LUHB 2008/04/23	
D	E1205-016	△ X 1	修改額定電流的規格	XJQ	2012/5/22		SCALE 比例 1/1 SIZE A4	PART NO. 產品料號 D03-0718-05001 DOC. NO. 文件編號 CUT-0718-001	
REV. 版本	ECN NO. 設變號碼	MARK 記號	REVISIONS 設變內容	SIGN 修改	DATE 日期				