

ITEM 項目	PARTS NAME 零件名稱	Q'TY 數量	MATERIAL 材質	FINISH/REMARK 處理/備註
1	HOUSING	1	SYNTHETIC RESIN	UL-94V-0 (Black)
2	CONTACT	22	COPPER ALLOY	Contact area: Au: 15u", Solder tails: Tin100u", Ni:50u"
3	LATCH	2	COPPER ALLOY	Ni:50", Tin:100u"
4	CAP	1	SYNTHETIC RESIN	UL-94V-0 (Black)

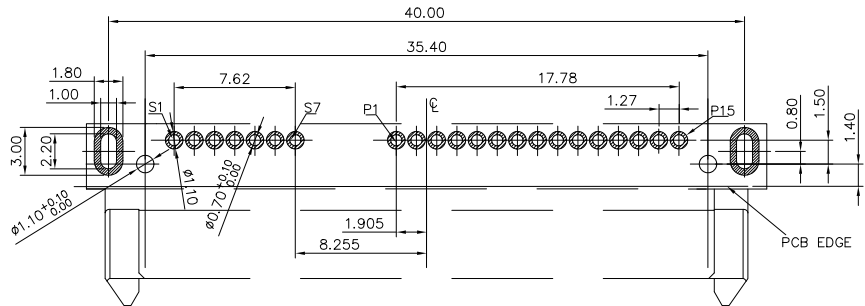

RECOMMENDED PCB LAYOUT
TOLERANCE ±0.05mm

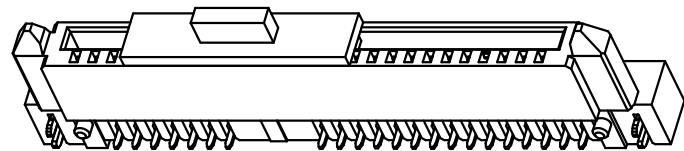

SPECIFICATION

- MATERIAL
See drawing
- STANDARD DATA
Rating current: 1.5A PER PIN
- ELECTRICAL
Insulator resistance: 1000M ohms Min. @ 500 VDC
Withstanding voltage: 500 VAC / minute
Contact resistance: 50 m ohms Max.
- MECHANICAL
Mating force: 20N(2.04kgf) Max.
Unmating force: 4N(0.41kgf) Min.
Durability: 500 cycles Min.
Contact retention force: 4.2N(0.43kgf) Min
- PART NO.

NAME	TYPE
P1	V33-1
P2	V33-2
P3	V33-3
P4	GND-4
P5	GND-5
P6	GND-6
P7	V5-1
P8	V5-2
P9	V5-3
P10	GND_7
P11	DAS/DSS
P12	GND_8
P13	V12_1
P14	V12_2
P15	V12_3

NAME	TYPE
S1	GND_1
S2	A+
S3	A-
S4	GND_2
S5	B-
S6	B+
S7	GND_3

SERIES A 4 2 - 0841 - 22 001
 A=Plug in
 TYPE MODEL NO. TYPE NO.
 4=1.27mm pitch 001=Type 1
 CONTACT TYPE CONTACT NUMBER
 2=DIP type 22=22 position



WALTA 華大電子股份有限公司
 WALTA ELECTRONIC CO.,LTD.
 TEL:886-2-26577778;FAX:886-2-26575659

REV. 版本	ECN NO. 設變號碼	MARK 記號	REVISIONS 設變內容	SIGN 修改	DATE 日期
B	E1709-001	△ X 1	設變加長CAP長度	Lonlon	2017/9/4
A	N2017-005	△ X 0	新開	Lonlon	2017/4/18

UNLESS OTHERWISE SPECIFIED TOLERANCE 尺寸公差	CHECKED 審核	DESIGNED 設計	TITLE 產品名稱
X. ±0.50	Lonlon	Lonlon	SATA 22PIN母座
.X ±0.30	APPROVED 承認	DRAWN 製圖	UNIT 單位 MM
.XX ±0.20	Lonlon	Lonlon	SCALE 比例 1/1
ANG. ±5'00"		2017/4/18	SIZE 尺寸 A4
			PART NO. 產品料號 A42-0841-22001
			DOC. NO. 文件編號 CUT-0841-002
			REV. 版本 B

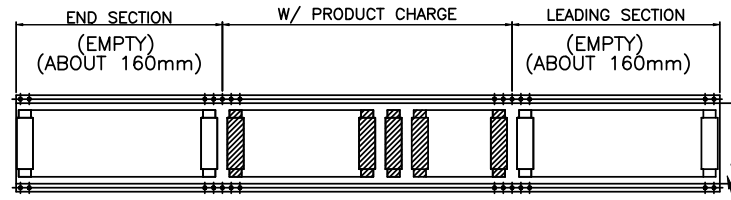
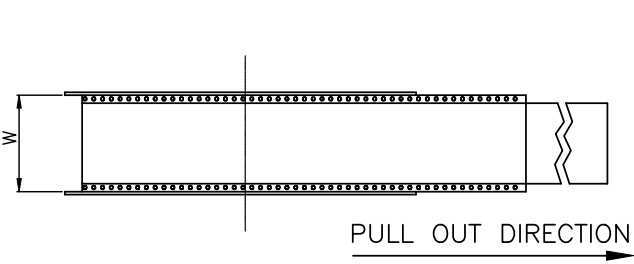

ITEM 項目	PARTS NAME 零件名稱	FINISH/REMARK 處理/備註
1	I/O CONNECTOR	2750 PCS/BOX(REFERENCE)
2	BOX	5 REEL/BOX
3	WATERPROOF BAG	1 PCS
4	REEL	--
5	COVER TAPE	(COLOR:TRANSPARENT)
6	CARRIER TAPE	550 PCS/REEL(REFERENCE)
7	LABEL	批號標籤

TOP COVER TAPE

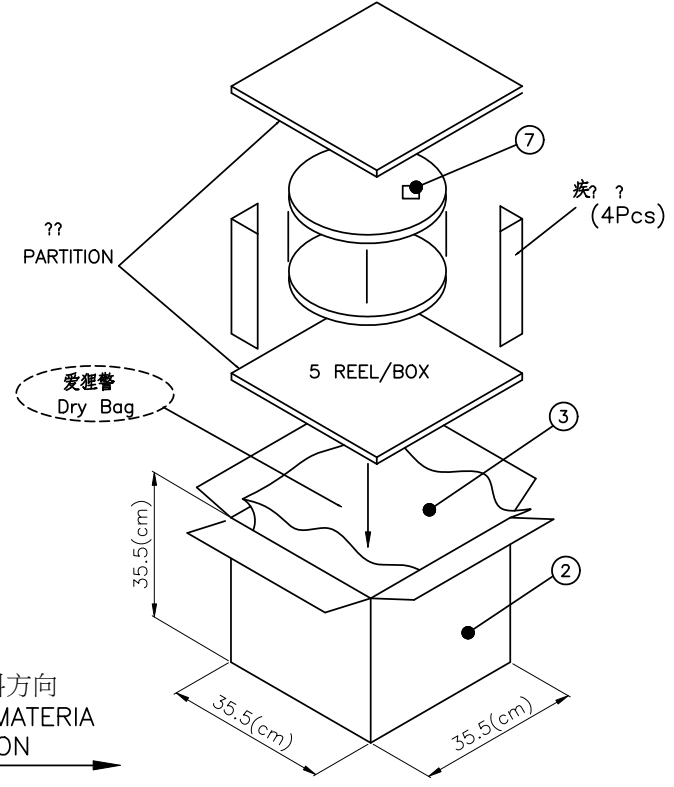
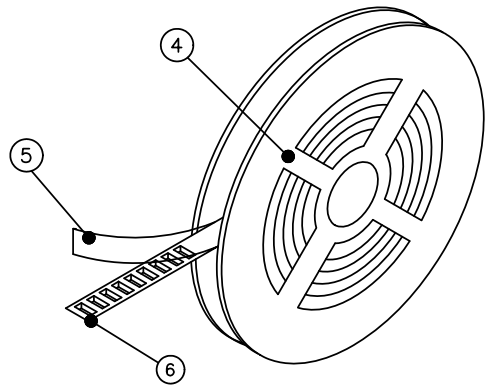
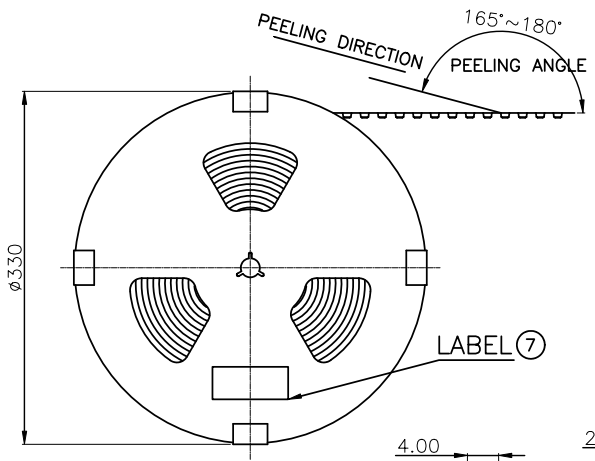

收料方向
CATHETER MATERIAL
DIRECTION

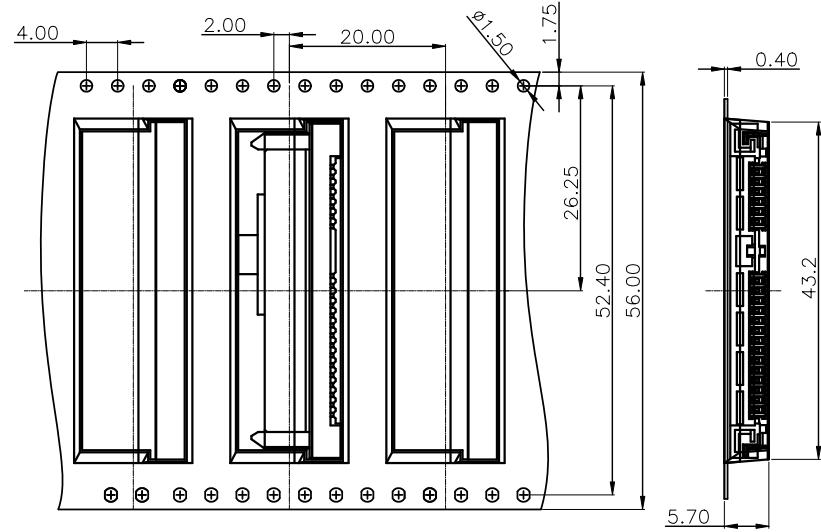

客戶放料方向
INPUT MATERIA
DIRECTION

- NOTES
- 1.MATERIAL: PS (Color: 透明)
 - 2.DEFORMATION(變形)&DAMAGE(損壞): NA.(不可)
 - 3.All dimensions meet EIA-481-C requirements.

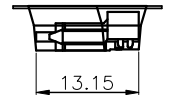

TAPE REEL成品擺放方向

Process Capable RoHS Compliant

WALTA 華大電子股份有限公司
WALTA ELECTRONIC CO.,LTD.
TEL:886-2-26577778;FAX:886-2-26575659

REV. 版本	ECN NO. 設變號碼	MARK 記號	REVISIONS 設變內容	SIGN 修改	DATE 日期	UNLESS OTHERWISE SPECIFIED TOLERANCE 尺寸公差	CHECKED 審核	DESIGNED 設計	SCALE 比例	TITLE 產品名稱	UNIT 單位	PART NO. 產品料號	REV. 版本
B	E1709-001	△ X 0	設變加長CAP長度	Lonlon	2017/9/4	X. ±0.50	2017/4/25	Lonlon	1/1	SATA 22PIN母座	MM	A42-0841-22001	2/2
A	N2017-005	△ X 0	新開	Lonlon	2017/4/25	.X ±0.30 .XX ±0.20 ANG. ±5'00"	2017/4/25	Lonlon	1/1	沉板式中心高0.6mm	MM	A42-0841-22001	B
1	2	3	4	5	6	7	8	9	10				