

ITEM 項目	PARTS NAME 零件名稱	Q'TY 數量	MATERIAL 材質	FINISH/REMARK 處理/備註
1	SHELL	1	SUS301	Ni:50u"
2	HOUSING	1	LCP-MG350BPRL	(Black)UL94V-0
3	GND SPRING	2	SUS304	NON PLATING
4	Insert molding	2	LCP-MG350BPRL	(Black)UL94V-0
5	CONTACT	22	C7035	Contact area:Gold flash, Solder tails:Tin100u", Ni:50u"
6	LATCH	1	SUS301	Ni:50u"
7	CAP	1	LCP-MG350BPRL	(Black)UL94V-0

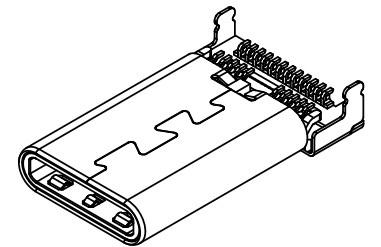

SPECIFICATION
MATERIAL
 See drawing
STANDARD DATA
 Rating current:
 5.0A for VBUS (i.e.,pins A4,A9,B4,B9)
 1.25A for Vconn and GND (i.e.,pins B5,A1,A12,B1,B12)
 0.25A for all the other contacts.
 Operating temperature: -10°C ~ +60°C
 Storage temperature: -20°C ~ +85°C
ELECTRICAL
 Insulator resistance: 100Mohms Min.
 Withstanding voltage: 100 VAC / minute
 Contact resistance: initial 40mohms Max;
 after 50mohms Max.

MECHANICAL
 Mating force: 5~20N
 Unmating force : Initial 8~20N
 After 10000 cycles 6~20N
 Durability: 10000 cycles Min.
PART NO.
 SERIES A 1 3 - 0848 - 22 001
 MODEL NO. TYPE NO. 001=Type 01
 CONTACT NUMBER 24=24 position
 TYPE
 1=0.5mm pitch
 CONTACT TYPE
 3=SMT type

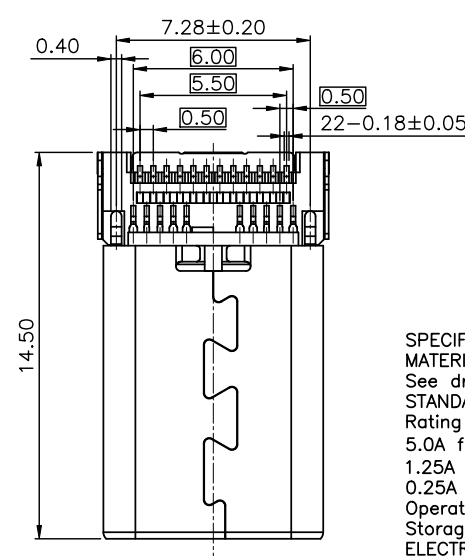
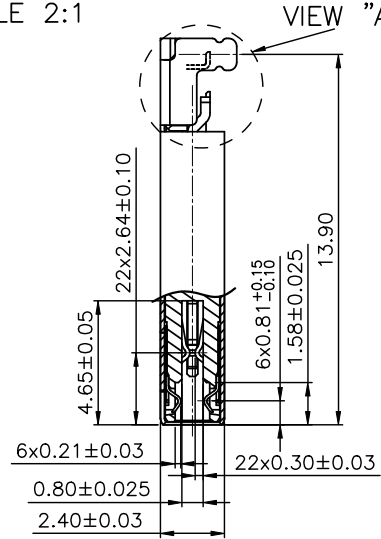
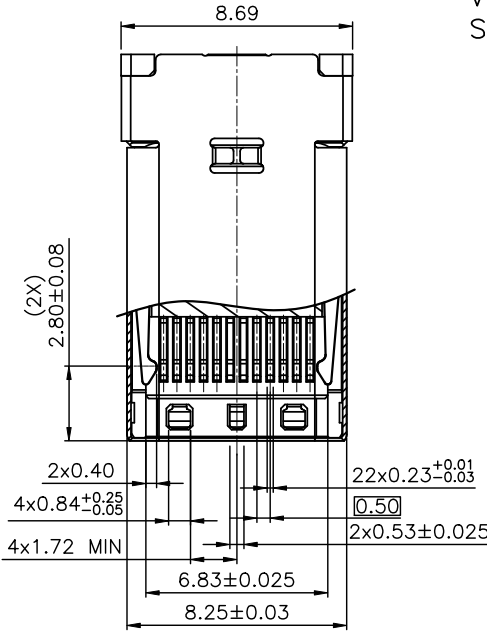
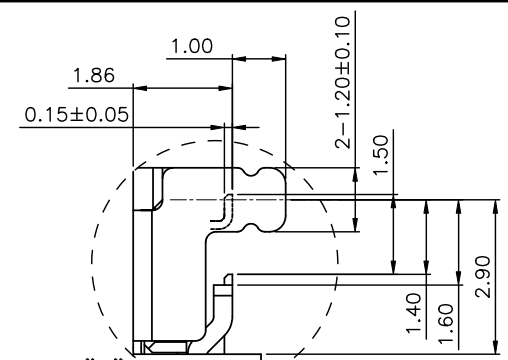
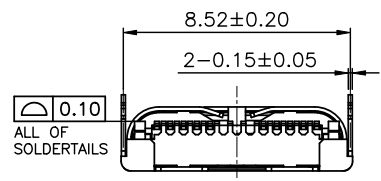
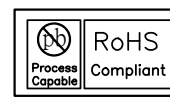
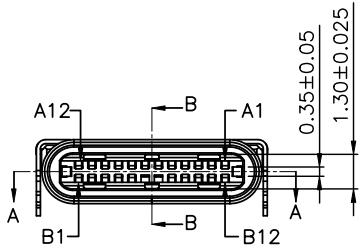
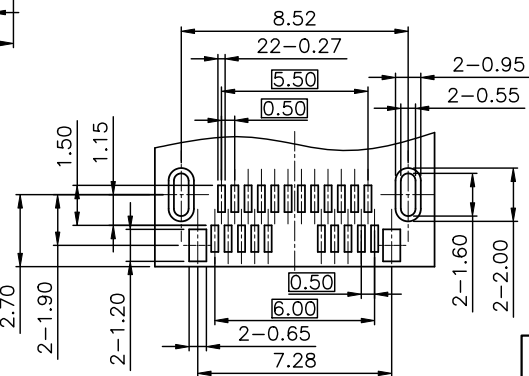

WALTA 華大電子股份有限公司
 WALTA ELECTRONIC CO.,LTD.
 TEL:886-2-26577778;FAX:886-2-26575659

REV. 版本	ECN NO. 設變號碼	MARK 記號	REVISIONS 設變內容	SIGN 修改	DATE 日期	UNLESS OTHERWISE SPECIFIED TOLERANCE 尺寸公差 X. ±0.50 .X ±0.25 .XX ±0.15 .XXX ±0.10 ANG. ±2'00'	CHECKED 審核	DESIGNED 設計 London 2018/6/6	DRAWN 製圖 London 2018/6/6	TITLE 產品名稱 UNIT 單位 SCALE 比例 SIZE 尺寸	PART NO. 產品料號 DOC. NO. 文件編號	REV. 版本
B	E2011-003	△ X 0	設變端子頭部通道頂部加膠,取消Mylar	CR	2020/11/30					USB3.1 TYPE-C PLUG SMT TYPE		1/3
A	N2018-003	△ X 0	新開	London	2018/6/6					A13-0848-22001		B

ITEM 項目	PARTS NAME 零件名稱	Q'TY 數量	MATERIAL 材質	FINISH/REMARK 處理/備註
1	SHELL	1	SUS301	Ni:50u"
2	HOUSING	1	LCP-MG350BPRL	(Black)UL94V-0
3	GND SPRING	2	SUS304	NON PLATING
4	Insert molding	2	LCP-MG350BPRL	(Black)UL94V-0
5	CONTACT	22	C7035	Contact area:Gold flash, Solder tails:Tin100u", Ni:50u"
6	LATCH	1	SUS301	Ni:50u"
7	CAP	1	LCP-MG350BPRL	(Black)UL94V-0

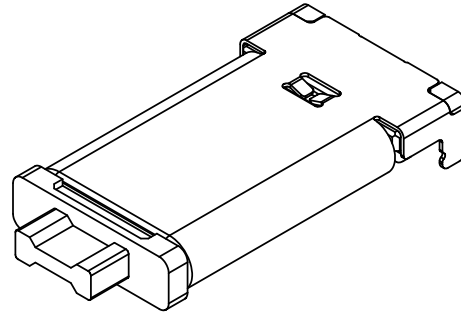
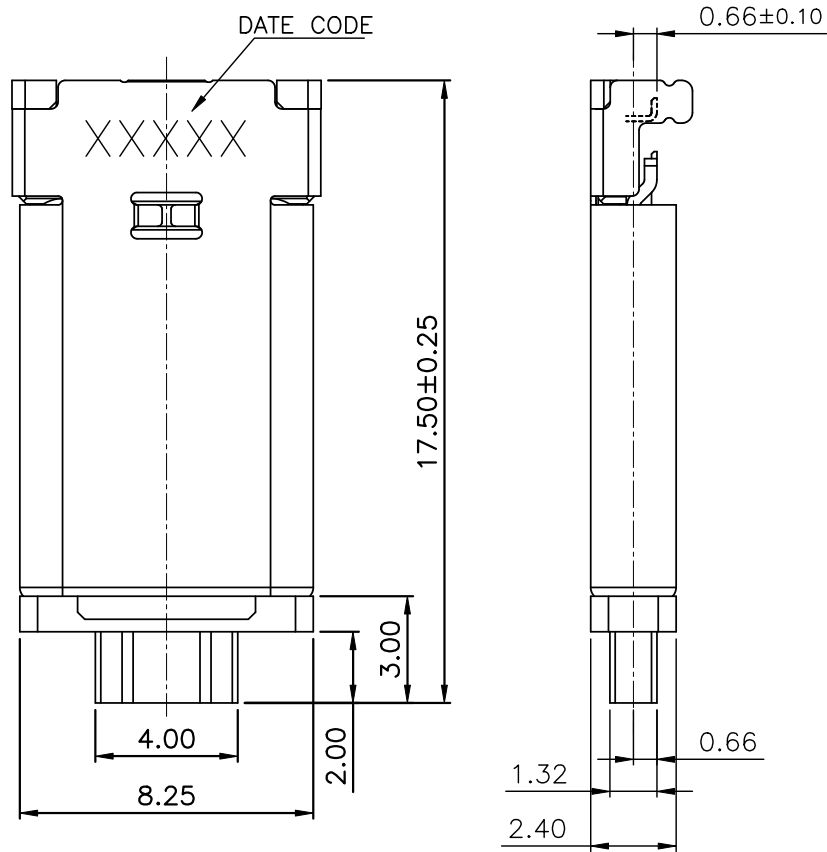

SPECIFICATION

MATERIAL

See drawing
STANDARD DATA

Rating current:

5.0A for VBUS (i.e.,pins A4,A9,B4,B9)

1.25A for Vconn and GND (i.e.,pins B5,A1,A12,B1,B12)

0.25A for all the other contacts.

Operating temperature: -10°C ~ +60°C

Storage temperature: -20°C ~ +85°C

ELECTRICAL

Insulator resistance: 100Mohms Min.

Withstanding voltage: 100 VAC / minute

Contact resistance: initial 40mohms Max;
after 50mohms Max.

MECHANICAL

Mating force: 5~20N

Unmating force : Initial 8~20N

After 10000 cycles 6~20N

Durability: 10000 cycles Min.

PART NO.

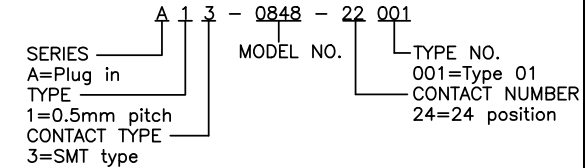

WITH CAP DRAWING



華大電子股份有限公司
WALTA ELECTRONIC CO.,LTD.
TEL:886-2-26577778;FAX:886-2-26575659

REV. 版本	ECN NO. 設變號碼	MARK 記號	REVISIONS 設變內容	SIGN 修改	DATE 日期	UNLESS OTHERWISE SPECIFIED TOLERANCE 尺寸公差 .X ±0.25 .XX ±0.15 .XXX ±0.10 ANG. ±2'00'	CHECKED 審核	DESIGNED 設計 Lonlon 2018/6/6	APPROVED 承認	DRAWN 製圖 Lonlon 2018/6/6	UNIT 單位 MM	TITLE 產品名稱 USB3.1 TYPE-C PLUG SMT TYPE	PART NO. 產品料號 A13-0848-22001	REV. 版本 B
B	E2011-003	△ X 0	設變端子頭部通道頂部加膠,取消Mylar	CR	2020/11/30									
A	N2018-003	△ X 0	新開	Lonlon	2018/6/6						SCALE 比例 1/1	DOC. NO. 文件編號 CUT-0848-001	2/3	

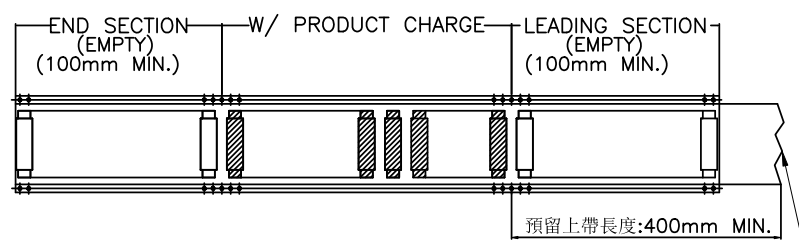
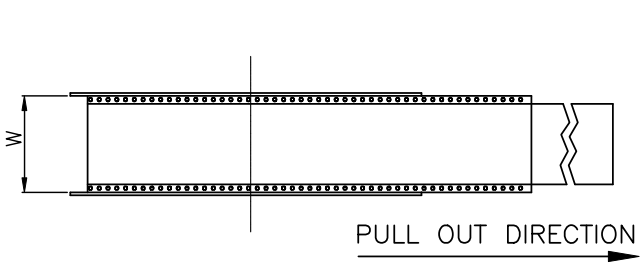

ITEM 項目	PARTS NAME 零件名稱	FINISH/REMARK 處理/備註
1	I/O CONNECTOR	9600 PCS/BOX(REFERENCE)
2	BOX	8 REEL/BOX
3	WATERPROOF BAG	1 PCS
4	REEL	--
5	COVER TAPE	(COLOR:TRANSPARENT)
6	CARRIER TAPE	1200 PCS/REEL(REFERENCE)
7	LABEL	批號標籤

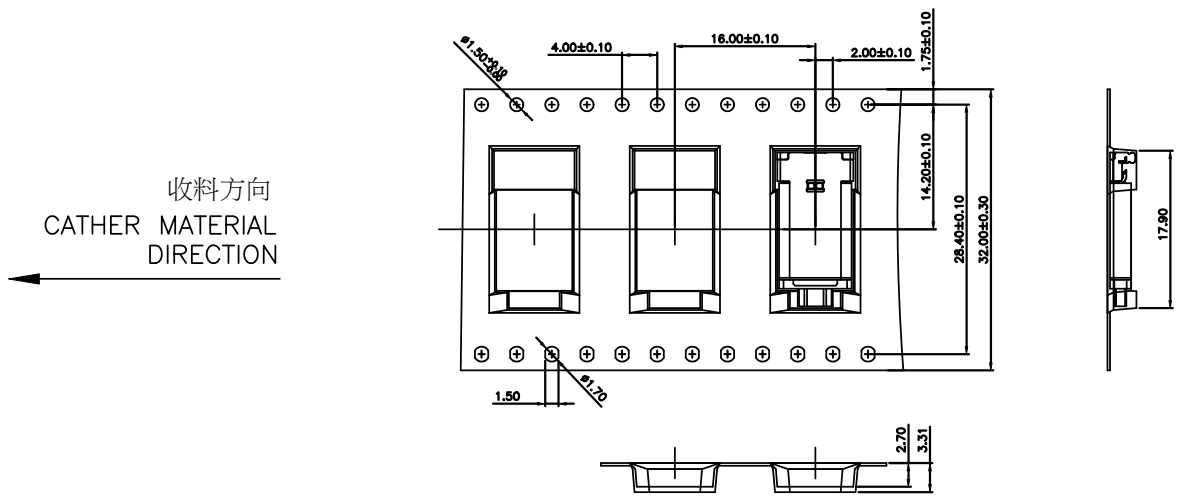
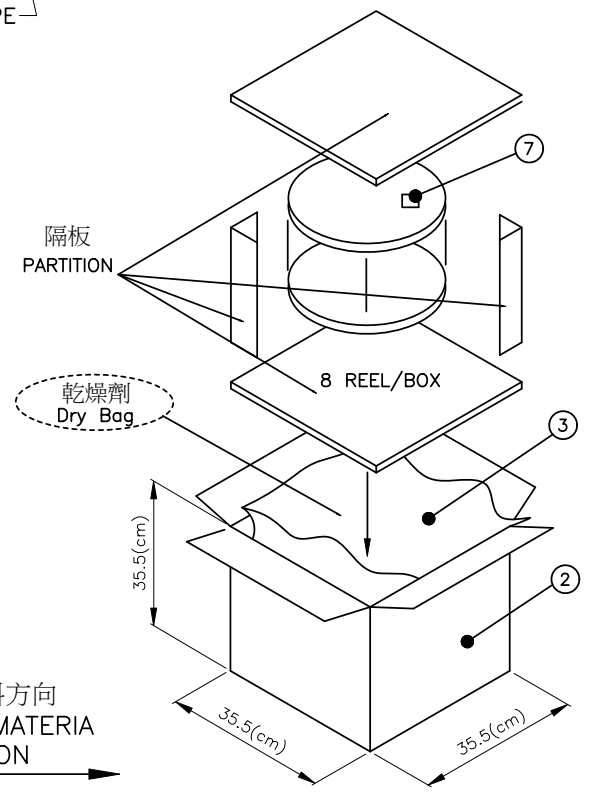
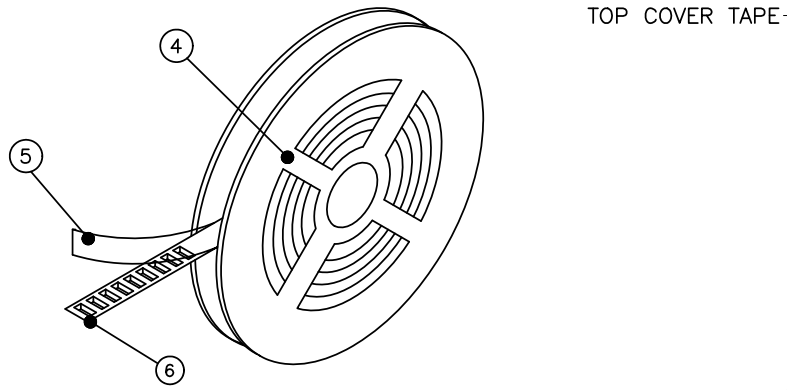
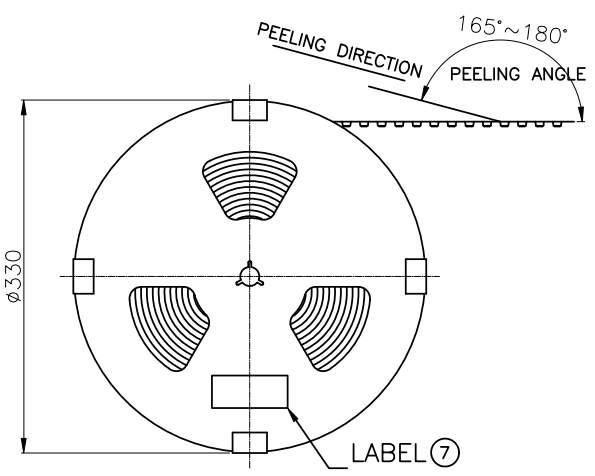

客戶放料方向
INPUT MATERIA
DIRECTION

TAPE REEL成品擺放方向

NOTES
1.MATERIAL: PS (Color: 透明)
2.DEFORMATION(變形)&DAMAGE(損壞): NA.(不可)
3.All dimensions meet EIA-481-C requirements.

RoHS Compliant

WALTA 華大電子股份有限公司
WALTA ELECTRONIC CO.,LTD.
TEL:886-2-26577778;FAX:886-2-26575659

REV. 版本	ECN NO. 設變號碼	MARK 記號	REVISIONS 設變內容	SIGN 修改	DATE 日期	UNLESS OTHERWISE SPECIFIED TOLERANCE 尺寸公差	CHECKED 審核	DESIGNED 設計	UNIT 單位	TITLE 產品名稱	PART NO. 產品料號	REV. 版本
B	E2011-003	X 0	設變端子頭部通道頂部加膠,取消Mylar	CR	2020/11/30	.X ±0.50	London	2018/6/6	MM	USB3.1 TYPE-C PLUG SMT TYPE	A13-0848-22001	3/3
A	N2018-003	X 0	新開	Lonlon	2018/6/6	.X ±0.30 .XX ±0.20 ANG. ±5'00"	London	2018/6/6	SCALE 1/1 SIZE A4	CUT-0848-001	B	